



2017

SILVERADO SPECIAL SERVICE





About This Publication

This catalog is not updated during the model year and should not be used for ordering purposes. It is intended as a source of basic information. All illustrations and specifications in this literature are based on the latest product information available at the time of publication. General Motors reserves the right to make changes at any time without notice. For further details, consult your local dealer.

Care must be taken during customer installation of equipment and wiring to ensure that all holes drilled in the body are corrosion protected, properly sealed and that vehicle wiring harnesses, piping or other components have not been displaced or damaged. Aftermarket equipment installers must be mindful of applicable Federal Motor Vehicle Safety Standards. This information can be obtained directly from the National Highway Traffic Safety Administration.

Adding non-dealer accessories or making modifications to the vehicle can affect vehicle performance, aerodynamics, and overall top speed.

These vehicles are equipped with an air bag system. The air bag system in your police vehicle includes frontal driver and passenger air bags, front seat back side impact air bags, front knee air bags or knee bolsters and side curtain air bags. Customer installed equipment such as security barriers behind the front seats should not be mounted so that the barrier ends are within the side air bag deployment zones. The sensors and other components for the air bag system must not be relocated to accommodate the installation of customer furnished equipment; please refer to the service manual for sensor and other component locations. For information concerning instrument panel top pad mounted equipment and air bag system deployment zones, see the air bag information section in this catalog and the vehicle owners manual.

A note about vehicle alterations by independent suppliers: This catalog shows pictures of vehicles that have been altered or upfitted with equipment or components supplied to Chevrolet or its dealers by independent suppliers. Chevrolet is not responsible for the safety or quality of design features, materials or workmanship of any alterations by a supplier.

INDEX

- **UPDATES FOR 2017 SILVERADO SPECIAL SERVICE CREW CAB**
- **STANDARD 5W4 FEATURES**
- **COLORS & INTERIOR TRIM**
- **POWERTRAIN / EMISSIONS / TIRES / PROJECTED TOP SPEEDS**
- **OPTIONAL EQUIPMENT**
- **SPECIFICATIONS**
- **ILLUSTRATION HIGHLIGHTS**
- **WIRING DIAGRAMS**
- **AIRBAG DIMENSIONS**
- **AIRBAGS & STABILITRAK**
- **WARRANTY**

SILVERADO SPECIAL SERVICE 5W4

Under-hood auxiliary battery

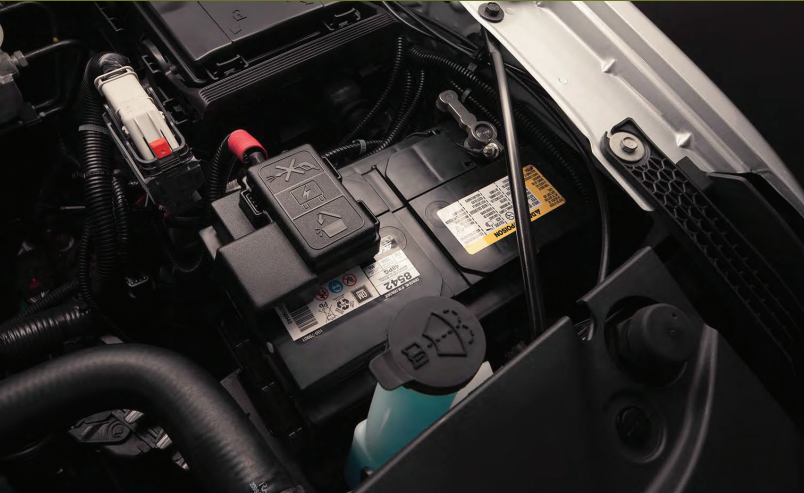

Vinyl 60/40 fold-up rear seating



Shown with aftermarket equipment and Kerr-installed Push-To-Talk steering wheel controls

UPDATES FOR 2017

NEW FEATURES

- **Wiring Provision Description**
- **Option (GC7) Lamp, Auxiliary Dome (Incandescent bulbs changed to LED)**
- **(GPA) Graphite Metallic exterior color**
- **(GMU) Pepperdust Metallic exterior color**
- **(PDV), Chrome Essentials Package**
- **Teen driver mode**
- **Capless Fuel Fill**
- **Aero shutters (See Standard Chassis Features for Description)**

DISCOUNTED

- **(G1C) Slate Grey Metallic**
- **(GXG) Tungston Metallic**
- **(G1F) Autumn Bronze Metallic**

NOTE: This vehicle is not designed nor intended for use in high speed emergency vehicle operations. Model CC15543 2WD and CK15543 4WD come with 1/2 ton fleetside short box (5.7 ft) crew cab. Model CC15743 2WD and CK15743 4WD come with 1/2 ton fleetside standard box (6.5 feet) crew cab.

INTERIOR FEATURES ON WT AND LS MODELS

AIR CONDITIONING	Single-zone
ASSIST HANDLES	Mounted for all outboard occupants. A-pillar handle deleted when 7X7 is ordered.
AUDIO SYSTEM	AM/FM stereo with USB port, Auxiliary jack and 4.2" diagonal color display. Includes 6-speaker audio system.
BLUETOOTH¹	Personal cell phone connectivity to vehicle audio system. (Available on WT model, standard on LS model)
CRUISE CONTROL	Electronic with set and resume speed, Steering wheel-mounted
DOOR LOCKS	Power
DRIVER INFO. CENTER	3.5-inch diagonal monochromatic display, provides warning messages and basic vehicle information
FLOOR COVERING	Graphite-colored rubberized-vinyl, floor mats not included
LIGHTING	Interior with dome and reading lights, illuminated entry feature and backlit instrument panel switches
MIRROR	Inside rearview day night
POWER OUTLET	12 volt DC outlet and 110 volt, 150 watt AC outlet in lower center instrument panel. 12 volt DC outlet is configurable to be Battery powered at all times or Ignition Control powered. See the Owners Manual for information about DC Outlet power configuration.
REMOTE KEYLESS ENTRY	Standard on LS model, includes 2 transmitters (Available on WT model with PCR fleet package) When PCR Fleet Package is ordered it deletes the passenger side key lock cylinder.
RESTRAINT SYSTEM²	Safety belts, driver and front passenger with pretensioners, dual stage driver and passenger frontal airbags, passenger sensing system and frontal airbag ON/OFF indicator, rollover sensor, dual head curtain airbags ³ for first and second row outboard occupants and front seat back mounted thorax-pelvic airbags
SEAT, FRONT	Front 40/20/40 split-bench, 3-passenger, driver and front passenger manual recline with outboard head restraints and center fold-down armrest with storage. Vinyl has fixed lumbar (standard on WT model). Cloth with manual adjustable driver lumbar (standard on LS model, optional on WT).
SEAT, REAR	60/40 vinyl bench (folds up), 3-passenger (includes child seat top tether anchor)
SPEEDOMETER/CLUSTER	6-gauge cluster featuring speedometer, fuel level, engine temperature, tachometer, voltage and oil pressure
STEERING COLUMN	Tilt-wheel with theft deterrent locking feature
TEEN DRIVER MODE	A configurable feature that can be programmed through your radio that lets you activate customizable vehicle settings associated with a key fob, to encourage safe driving behavior. It can limit certain vehicle features, and it prevents certain safety systems from being turned off. An in-vehicle report gives you information on your driving habits.
VISORS	Driver and front passenger, sliding with clip and illuminated passenger vanity mirror
WARNING TONES	Headlamp on, key-in-ignition, driver and passenger buckle up reminder and turn signal on
WINDOWS	Power front and rear with (driver express up and down) and express down on all others windows

1. The Bluetooth word mark is a registered trademark owned by Bluetooth SIG, Inc. and any use of such mark by GM is under license. Go to gm.com/bluetooth to find out which Bluetooth phones are compatible with the vehicle.

2. Does not include emergency or security services. Visit onstar.com for coverage map, details and system limitations

3. Always use safety belts and the correct child restraint for your child's age and size, even in vehicles equipped with airbags. Even in vehicles equipped with Passenger Sensing System, children are safer when properly secured in a rear seat in an appropriate infant, child or booster seat. Never place a rear-facing infant restraint in the front seat of any vehicle equipped with an active frontal airbag. See your vehicle Owner Manual and child safety seat instructions for more information.

EXTERIOR FEATURES ON WT AND LS MODELS

BUMPER FRONT	Black (Chrome standard on LS model). Chrome available on WT model with PCX package.
BUMPER REAR	Black with corner step (Chrome standard on LS model). Chrome available on WT model with PCX package.
CAPLESS FUEL FILL	The vehicle has a capless refueling system and does not have a fuel cap. The filling nozzle must be fully inserted and latched prior to starting fuel flow. NOTE: Overfilling the fuel tank by more than three clicks of a standard fill nozzle may cause; vehicle performance issue, including engine stalling and damage to the fuel system, fuel spills, potential fuel fires
DOOR HANDLES	Black
GLASS	Solar absorbing (Deep-tinted rear glass standard on LS model) available on WT model.
GRILLE	Black surround (Chrome surround standard on LS model)
HEADLAMPS	High intensity discharge (HID) projector-beam with LED signature DRL. Altering headlamp assembly is not recommended, General Motors is not responsible for the effects of any modifications.
LAMPS	Cargo area, cab mounted with separate switch on center switch bank
MIRRORS, OUTSIDE	Manual, Black (Heated power- adjustable includes driver's side spotter mirror standard on LS model, available on WT model)
RADIO ANTENNA	Most type located on passenger side front fender
RECOVERY HOOKS	Two black front frame-mounted. Standard on 4 wheel drive. Optional on 2 wheel drive, see Option equipment section for description
TAILGATE	Locking, utilizes same key as ignition and door, includes tailgate and bed rail protection cap. Remote locking tailgate standard on LS model. Available on WT model with PCR Convenience package (see available options page for description).
TIRES	P255/70R17 all-season, blackwall (includes P255/70R17 All-season blackwall spare tire)
TIRE, SPARE CARRIER	Keyed cylinder lock utilizes same key as ignition and door
WHEELS	17" x 8" steel painted Standard on WT model available on LS model. (17" x 8" Stainless steel clad standard on LS model, not available on WT model)
WHEEL, SPARE	Full-size 17" black steel
WINDSHIELD WIPERS	Intermittent wet-arm with pulse washers

CHASSIS FEATURES ON WT AND LS MODELS

AERO SHUTTERS	Aero shutters are designed to close when operating conditions permit. The shutters are located on the front of the A/C condenser under hood to divert airflow around the front of the truck reducing wind drag and improves fuel economy. When the cooling system requires more air flow the shutters automatically reopen, ensuring proper air flow through the radiator
AIR CLEANER	High capacity
ALTERNATOR	170-amp, high-output
BATTERIES	Heavy-duty 720-CCA primary (80-amp hour) and isolated heavy-duty 730-CCA auxiliary (70-amp hour)
BRAKES	4-wheel disc with DURALIFE rotors, 4-wheel antilock
ENGINE	5.3L EcoTec3 V8 with Active Fuel Management, Direct Injection and Variable Valve timing, includes aluminum block construction
EXHAUST	Aluminized stainless-steel muffler and tailpipe
FRAME	Fully-boxed, hydroformed front section
FUEL TANK	Approximately 26 gallon (98 liter)
OIL COOLING	External engine oil cooler and auxiliary transmission oil cooler
REAR AXLE	3.08 ratio
STABILITRAK	Stability control system with Proactive Roll Avoidance and traction control includes electronic trailer sway control and hill start assist (see standard equipment illustrations section)
STEERING	Electric Power Steering (EPS) assist, rack-and-pinion
SUSPENSION, FRONT	Independent, coil over shock, includes 35mm twin tube shock absorbers and 36mm front stabilizer bar
SUSPENSION, REAR	2-Stage multi-leaf springs, semi-elliptic
TIRE PRESSURE MONITOR	Tire Pressure Monitoring System. Standard spare wheel not equipped with TPM sensor. Optional spare wheel SEO (OOA) includes TPM sensor.
TRANSFER CASE	4WD model only, manual transfer case (floor mounted). See optional equipment section for description of dash mounted Autotrac (NQH).
TRANSMISSION	6-speed automatic electronically controlled with overdrive and tow/haul mode. Includes Cruise Grade Braking and Powertrain Grade Braking
WARRANTY	See Maintenance and Warranty section for description

FRONT SEATS AND INTERIOR TRIM

STANDARD - Vinyl Split-Bench (AE7) on WT Model (Vinyl not available on LS model)

40/20/40 split-bench, 3-passenger, driver and front passenger manual recline with outboard head restraints, center fold-down armrest with storage, and fixed lumbar. Seats are manual (power not available).

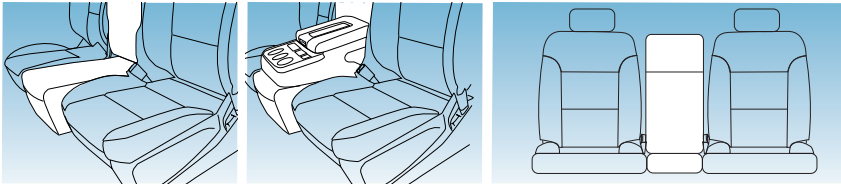

Seat Code	Seat Trim	Color	Color Code
AE7	Vinyl	Dark Ash w/ Jet Black Accents	H2Q

- Center seat can be unbolted for removal

OPTIONAL - CENTER SEAT DELETE SEO (9S1) VINYL

Seats, driver and passenger front, individual seats in vinyl trim. Driver and passenger front individual seats in base vinyl trim. Derived from a RPO (AZ3) 40-20-40 split bench seat with the 20% section removed. Seats are manual, not power. Does not include a floor console. All exposed floor area will remain untrimmed. Rear seat will also be vinyl trimmed. Requires (AZ3) 40/20/40 split bench seat, trim code (H2G) Jet Black vinyl and (BG9) rubberized-vinyl floor covering.

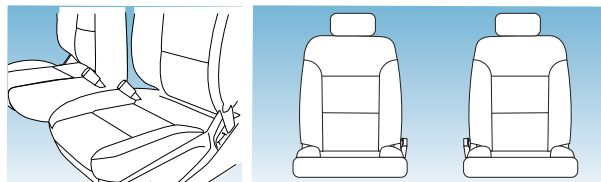

Seat Code	Seat Trim	Color	Color Code
AE7	Vinyl	Dark Ash w/ Jet Black Accents	H2Q

OPTIONAL - CLOTH MANUAL SPLIT BENCH (AE7)

Front 40/20/40 Split-Bench 3-passenger. Driver and front passenger manual recline with outboard head restraints and center fold-down armrest with storage and manual adjustable driver lumbar. Seats are manual (power not available).

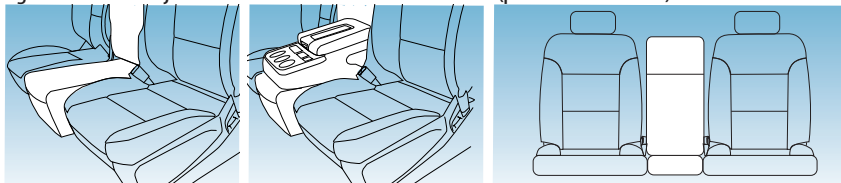

Seat Code	Seat Trim	Color	Color Code
AE7	Cloth	Dark Ash w/ Jet Black Accents	H2R

- Center seat can be unbolted and removed
- Front cloth and vinyl rear seat combination is available by ordering option (ST5).

OPTIONAL - 9U3 CLOTH

Seats, Driver and passenger front individual seats in cloth trim. Power driver and passenger bucket seats in base cloth trim. Derived from RPO (AZ3) 40-20-40 split bench seat with the 20% section removed. Does not include a floor console. All exposed floor area will remain untrimmed. Requires (AZ3) 40/20/40 split bench seat, trim code and (HOU) Jet Black cloth.

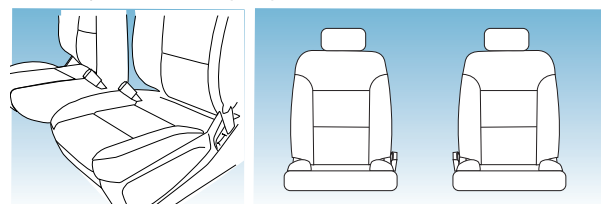

Seat Code	Seat Trim	Color	Color Code
AE7	Cloth	Dark Ash w/ Jet Black Accents	H2R

- Front cloth and vinyl rear seat combination is available by ordering option (ST5).

OPTIONAL - CLOTH SPLIT-BENCH (AZ3) WITH POWER DRIVER SEAT

Seats, front 40/20/40 split-bench, with Premium Cloth, 3-passenger. Includes 6-way power driver and 2 way front passenger seat adjuster, driver and front passenger power lumbar control and power reclining, center fold-down armrest with storage, storage compartments in seat cushion, adjustable outboard head restraints and storage pockets

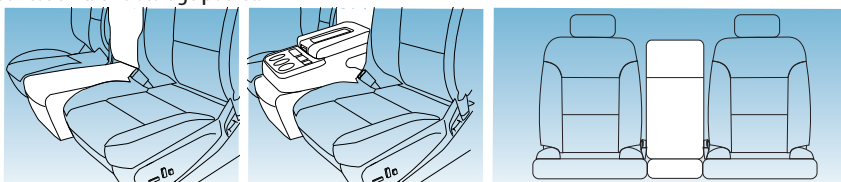

Seat Code	Seat Trim	Color	Color Code
AZ3	Cloth	Dark Ash w/ Jet Black Accents	H2R
AZ3	Cloth	Jet Black	HOU

- Center seat can be unbolted and removed
- Front cloth and vinyl rear seat combination is available by ordering option (ST5).

REAR SEATS AND INTERIOR TRIM

STANDARD - A68 VINYL REAR SEAT

Vinyl rear bench 60/40 split-folding seat. Includes folding center armrest with cup holders

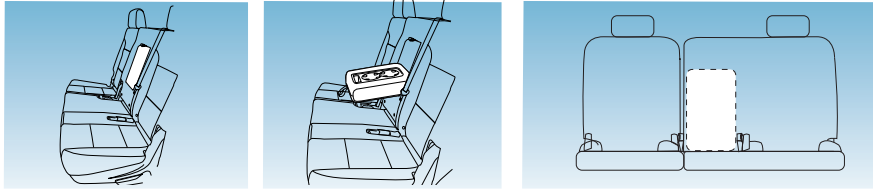

Seat Code	Seat Trim	Color	Color Code
A68	Vinyl	Dark Ash w/ Jet Black Accents	H2Q

• Cloth rear seat available in Dark Ash with Jet Black Accents by ordering (H2R) trim

OPTIONAL— SEO (5T5) CLOTH FRONT SEATS WITH VINYL REAR SEATS

Vinyl Rear 60/40 Split-folding Bench Seat. Requires (AE7) or (AZ3) cloth front 40/20/40 split-bench seat and (H2R) Dark Ash

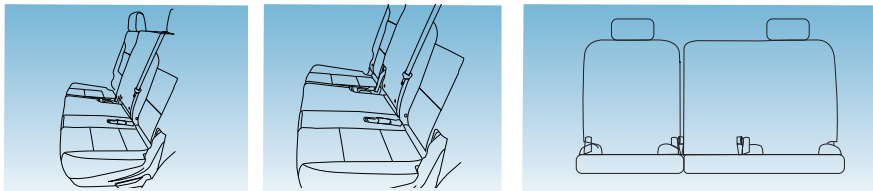

Seat Code	Seat Trim	Color	Color Code
5T5	Vinyl	Dark Ash w/ Jet Black Accents	H2Q

• Front cloth and vinyl rear seat combination is available by ordering option 5T5 in Dark Ash with Jet Black Accents

AVAILABLE INTERIOR COLOR Actual colors may vary



H2R
Dark Ash Cloth
with Jet Black
Accents



H2Q
Dark Ash Vinyl
with Jet Black
Accents



H0U
Jet Black cloth
with AZ3 only

AVAILABLE EXTERIOR COLORS Actual colors may vary



G7C
Red Hot



GPA
Graphite
Metallic



GAN
Silver Ice
Metallic



GAZ
Summit White



GBA
Black



G1K
Deep Ocean
Blue Metallic*



GMU
Pepperdust
Metallic

*Additional charge

SEO PAINT AVAILABLE

COLOR DESCRIPTION	SEO CODE	WA#
Woodland Green	9V5	9015
Doeskin Tan	NONE	9403
Wheatland Yellow (86U)	9W3	253A
Tangier Orange	9W4	9417
Blue Metallic	NONE	7159
Dark Toreador Red	NONE	334D
Unripened Green Metallic	NONE	136X
Indigo Blue	NONE	9792
Light Autumnwood Metallic	NONE	228A
Pewter	NONE	382E
Actual Color May Vary		

POWERTRAIN

ENGINE				TRANSMISSION		AXLE	
OPTION CODE	TYPE	DISPLACEMENT LITERS/CU. IN.	FUEL SYSTEM	OPTION CODE	TYPE	OPTION CODE	RATIO
L83	V8	5.3/325	Active fuel management	MXO/MYC	6L80 6-speed auto. with OD	GU4	3.08

EMISSIONS - MUST BE SPECIFIED

FE9 EMISSIONS, Federal requirements

NE1 EMISSIONS, CONNECTICUT, Delaware, Maine, Maryland, Massachusetts, New Jersey, New York, Oregon, Pennsylvania, Rhode Island, Vermont and Washington state requirements

NB8 EMISSIONS OVERRIDE, California (allows a dealer in states that require California emissions - California, Connecticut, Delaware, Maryland, Massachusetts, New Jersey, New York, Oregon, Pennsylvania, Rhode Island or Washington - to order Federal emissions for a vehicle that will be registered in a state that has Federal emission requirements). Do not use for vehicles that will be registered in California, Connecticut, Delaware, Maryland, Massachusetts, New Jersey, New York, Oregon, Pennsylvania, Rhode Island or Washington. **Requires (FE9) Federal emissions requirements. Not available in Maine or Vermont.**

NB9 EMISSIONS OVERRIDE, State-specific (for dealers ordering vehicles in (YF5) or (NE1) emission states - California, Connecticut, Delaware, Maine, Maryland, Massachusetts, New Jersey, New York, Oregon, Pennsylvania, Rhode Island, Vermont and Washington) **Allows a California dealer (YF5 emissions) to order (NE1) emissions with (NB9) emissions override code for registration in (NE1) states; or, a Connecticut, Delaware, Maine, Maryland, Massachusetts, New Jersey, New York, Oregon, Pennsylvania, Rhode Island, Vermont and Washington dealer (NE1 emissions) to order (YF5) emissions with (NB9) emissions override code for registration in California.**

NC7 EMISSIONS OVERRIDE, Federal (for vehicles ordered by dealers in Federal emission states with (YF5) or (NE1) emissions - Not required for vehicles being shipped to California, Connecticut, Delaware, Maine, Maryland, Massachusetts, New Jersey, New York, Oregon, Pennsylvania, Rhode Island, Vermont or Washington) **Requires (YF5) California state emissions requirements or (NE1) Connecticut, Delaware, Maine, Maryland, Massachusetts, New Jersey, New York, Oregon, Pennsylvania, Rhode Island, Vermont or Washington state emissions requirements.**

YF5 EMISSIONS, California state requirements

SPEEDOMETER CERTIFICATION IS NOT DISPLAYED ON VEHICLE

Silverado Special Service Vehicle speedometer calibration. Specifications at temperatures of -10 to 120 degrees F (-23 to 49 Celsius). Inaccuracies due to vehicle speed sensing are included. This vehicle is equipped with an electronically controlled speedometer which is designed to be accurate to +/- 2 mph through its range of function.

STANDARD TIRES - SPEED RATED

MANUFACTURER	QUANTITY	SIZE	SPEED RATING	TYPE
Random	5	P255/70R17	S	All-season, BW

PROJECTED TOP SPEED WITH STANDARD AND OPTIONAL TIRES¹

Tire Size	Vehicle Description	3.08 Ratio	3.42 Ratio
P225/70R17 (Standard)	2WD Short Box	106 mph	98 mph
P265/70R17 (Optional)	2WD Short Box	106 mph	98 mph
LT265/70R17C (Optional)	2WD Short Box	98 mph	98 mph
P225/70R17 (Standard)	2WD Long Box	112 mph	112 mph
P265/70R17 (Optional)	2WD Long Box	112 mph	112 mph
LT265/70R17C (Optional)	2WD Long Box	98 mph	98 mph
P225/70R17 (Standard)	4WD Short Box	98 mph	98 mph
P265/70R17 (Optional)	4WD Short Box	98 mph	98 mph
LT265/70R17C (Optional)	4WD Short Box	98 mph	98 mph
P225/70R17 (Standard)	4WD Long Box	112 mph	98 mph
P265/70R17 (Optional)	4WD Long Box	112 mph	98 mph
LT265/70R17C (Optional)	4WD Long Box	96 mph	96 mph

1. Adding accessories or making modifications to the vehicle can affect vehicle performance, aerodynamics, and overall top speed.

TRAILERING SPECS - Automatic Transmission Ratings with Ball Hitch (L83) 5.3L EcoTec3 V8 AFM DI VVT aluminum block

Model	Axle Ratio	Maximum Trailer Towing lbs. (kg)	Axle Ratio	Maximum Trailer Towing lbs. (kg)
CC15543	3.08	6400 (2903)	3.42	9400 (4264)
CK15543	3.08	6100 (2767)	3.42	9100 (4128)
CC15743	3.08	6300 (2858)	3.42	9300 (4218)
CK15743	3.08	6100 (2767)	3.42	9100 (4128)

Maximum Trailer Towing Rating is calculated based on SAE J2807 (Base vehicle plus one driver plus one passenger plus options). The weight of other optional equipment, passengers and cargo will reduce the Maximum Trailer Towing your vehicle can tow.

GCWR For Engine/Rear Axle Ratio Combination - Automatic Transmission

Engine	(GCWR) Gross Combination Weight Ratings lbs. (kg)			
(L83) 5.3L EcoTec3	3.08	12000 (5443)	3.42	14000 (6350)
			3.42	15000 (6804)

TRAILERING SPECS - Automatic Transmission Ratings with 5th Wheel (L83) 5.3L EcoTec3 V8 AFM DI VVT aluminum block

Model	Axle Ratio	Maximum Trailer Towing lbs. (kg)	Axle Ratio	Maximum Trailer Towing lbs. (kg)
CC15743	3.08	6300 (2858)	3.42	8600 (3901)
CK15743	3.08	6000 (2722)	3.42	8100 (3674)

Maximum Trailer Towing Rating is calculated based on SAE J2807 (Base vehicle plus one driver plus one passenger plus options). The weight of other optional equipment, passengers and cargo will reduce the Maximum Trailer Towing your vehicle can tow.

GCWR For Engine/Rear Axle Ratio Combination - Automatic Transmission

Engine	(GCWR) Gross Combination Weight Ratings lbs. (kg)			
(L83) 5.3L EcoTec3	3.08	12000 (5443)	3.42	14000 (6350)

OPTIONAL EQUIPMENT & FEATURES

INTERIOR

IOB	CHEVROLET MYLINK AUDIO SYSTEM , 7" diagonal color touch-screen, AM/FM stereo with seek-and-scan and digital clock, includes Bluetooth streaming audio for music and select phones. Includes (UQ3) 6-speaker audio system. (Available on WT Model, Standard on LS Model).
C49	DEFOGGER , Rear-window electric
B30	FLOOR COVERING , Color-keyed carpeting with rubberized vinyl floor mats (includes second row floor mats)
VAV	FLOOR MATS , All-weather, front and rear. Requires (B30) color-keyed carpeting
6C7	LIGHTING , Red and white auxiliary dome lamp is located on headliner between front row seats (red is LED, white is incandescent). The auxiliary lamp is wired independently from standard dome lamp. Includes (GEZ) Ship/Thru to Kerr Industries. Not available with (TRW) Provision for cab roof-mounted lamp/beacon.
UE1	ONSTAR GUIDANCE¹ "OnStar Guidance Plan for a limited time period. Includes Automatic Crash Response, Stolen Vehicle Assistance, Roadside Assistance, Turn-by-Turn Navigation, Advanced Diagnostics and more (trial excludes Hands-Free Calling)". Visit www.onstar.com for coverage map, details and system limitations. Services vary by model. OnStar acts as a link to existing emergency service providers. Not all vehicles may transmit all crash data. Standard on "LS" Model available. Includes: OnStar ³ Basic Plan for 5 years, includes limited vehicle mobile app features, Monthly Diagnostics Report and Dealer Maintenance Notification". Includes OnStar Basic Plan ² available for 5 years from the date of vehicle delivery and is transferable. Does not include Emergency, Security or Navigation services. Standard on "LS" Model. NOTE: Activation of an OnStar account requires the request of customer to initiate once vehicle is received.
VV4	ONSTAR WITH 4G LTE³ , "OnStar 4G LTE and built-in Wi-Fi hotspot connects to the Internet at 4G LTE speeds; includes OnStar Data Trial for 3 months or 3GB (whichever comes first)". Visit www.onstar.com for coverage map, details and system limitations. Services vary by model. OnStar acts as a link to existing service providers. Not all vehicles may transmit all crash data. Available Wi-Fi requires compatible mobile device, active OnStar service and data plan. Data plans provided by ATandT." Standard on "LS" Model.
VBJ	REAR UNDERSEAT STORAGE , composite storage bin dealer-installed Included with (PDL) Cargo Convenience Package
AGQ	REMOTE KEYLESS ENTRY Includes 2 transmitters (Included and only available with (PCR) WT Fleet Convenience Package. Includes (A91) remote locking tailgate). Standard on 'LS' Model.
AG1	SEAT ADJUSTER , Driver 10-way power, Included and only available with (AZ3) front 40/20/40 split-bench cloth seat. Requires (H2R) Dark Ash or (H0U) Jet Black seat trim.
9S1	SEATS , driver and passenger front, individual seats in vinyl trim. Driver and passenger front individual seats in base vinyl trim. Derived from a RPO (AE7) 40-20-40 split bench seat with the 20% section removed. Seats are manual, not power. Deletes USB and auxiliary power outlet. Does not include a floor console. All exposed floor area will remain untrimmed. Standard vinyl rear seat with trim matching front seats will be provided.
9U3	SEAT DELETE FRONT CENTER , Driver and Passenger front individual seats in base cloth trim. Derived from RPO (AE7) 40/20/40 split bench seat with 20% center section removed. Seats are manual and power is not available with center seat delete option. Also deletes USB, auxiliary input, and power outlet normally found in center seat. Rear seats trimmed in matching cloth; see option (5T5) for vinyl. Center seat delete exposes floor area and will remain untrimmed.
AZ3	SEATS , Cloth front 40/20/40 split-bench. Includes 6-way power driver and 2 way front passenger seat adjuster, driver and front passenger power lumbar control and power reclining, center fold-down armrest with storage, storage compartments in seat cushion, adjustable outboard head restraints and storage pockets
5T5	SEATS , Second Row Vinyl with Cloth Front 40/20/40 split-bench seat (AE7) or (AZ3) and (H2R) Dark Ash Cloth.
U2K	SIRIUS XM SATELLITE RADIO , Enjoy a 3-month All Access trial subscription with over 150 channels including commercial-free music, plus sports, news and entertainment. Plus listening on the app and online is included, so you'll hear the best SiriusXM has to offer, anywhere life takes you. Available on 1WT Models, Requires (IOB) 7" diagonal color display radio with Chevrolet MyLink and (UE1) OnStar. IMPORTANT: Fees and taxes apply. To cancel you must call us at 1-866-635-2349. See our Customer Agreement for complete terms at www.siriusxm.com . All fees and programming subject to change.
5L5	THEFT DETERRENT SYSTEM , In the absence of master key, fleet immobilizer modification reduces roadside key relearn process to (3) two-minute cycles in place of the standard (3) ten-minute cycles

1. Visit onstar.com for coverage map, details and system limitations

2. Does not include emergency or security services. Visit onstar.com for coverage map, details and system limitations

3. 4G LTE service available in select markets. Visit onstar.com for coverage map, details and system limitations.

OPTIONAL EQUIPMENT & FEATURES

EXTERIOR

BVQ	ASSIST STEPS , chromed tubular, 6" rectangular (factory installed) Not available with any dealer-installed assist steps (RVQ), (RVS) or (VXJ).
RVS	ASSIST STEPS , Black tubular assist steps, 4" round, Not available with (BVQ) Chrome tubular assist steps.
VZX	BED LINER , Included with (PDM) Bed protection package
CGN	BED LINER , Spray-on, Pickup box bed liner with bowtie logo. Liner is permanently bonded to the truck bed providing a water tight seal. The textured, non-skid surface is black in color and robotically applied. Spray-on liner covers entire bed interior surface below side rails, including tailgate, front box top rail, gage hole plugs and lower tie down loops. Included with (PDL) Cargo Convenience Package. Not available with (VZX) bed liner
CTD	CARGO TIE DOWNS , Four, movable upper. Included with (PDM) Bed protection package or (PDL) Cargo convenience package.
PCX	CHROME BUMPER PACKAGE , includes (VJH) rear chrome bumper with (BWN) CornerSteps and (V46) chrome front bumper
PDV	CHROME ESSENTIALS PACKAGE Includes (VQY) chrome recovery hooks and (VQZ) polished exhaust tip, LPO
9GB	DAYTIME RUNNING LAMPS DELETE . Daytime Running Lamps and automatic headlamp control delete, deletes standard Daytime Running Lamps and automatic headlamp control features from the vehicle for police stealth surveillance.
9M4	DECAL AND NAME PLATE DELETE , tailgate. Deletes all nameplates and decals on the pickup box tailgate. Not available with SEO (8F2) ornamentation delete.
9R1	DECAL DELETE , Pickup box Deletes the "4x4" decal from the side of the pickup box. Requires 4WD models only. Not available with SEO (8F2) ornamentation delete
AKO	GLASS , Deep-tinted (all windows, except light-tinted glass on windshield and driver- and front passenger-side glass)
6E2	KEY COMMON , Complete vehicle fleet. Provides a single key with a specific code that is common to the door locks and ignition of all the vehicles in the vehicle fleet. Key code is an alternate to SEO(6E8) complete vehicle fleet common key.
6E8	KEY COMMON , Complete vehicle fleet. Provides a single key with a specific code that is common to the door locks and ignition of all the vehicles in the vehicle fleet. Key code is an alternate to SEO(6E2) complete vehicle fleet common key.
5H1	KEY EQUIPMENT , Two additional keys for single key system. Provides two additional spare keys for a total of (4). (Keys will be cut but not programmed). Programming of keys is at customer's expense. Programming keys is not a warranty claim.
BX1	LABEL , fasten safety belts. "Fasten Safety Belts" reminder label on right hand and left hand front side door glass
UF2	LED LIGHTING , cargo box with switch on center switch bank
VK3	LICENSE PLATE KIT , front (will be shipped to orders with ship-to states that require front license plate)
DPN	MIRRORS , outside heated power-adjustable vertical camper, upper glass, manual-folding and extending, black. Includes integrated turn signal indicators consisting of 51 square inch flat mirror surface positioned over a 24.5 square inch convex mirror surface with a common head and lower convex spotter glass (convex glass is not heated and not power adjustable) and addition of Auxiliary cargo lamp for backing up (helps to see trailer when backing up with a trailer) and amber auxiliary clearance lamp Requires (PCR) WT Fleet Convenience Package. Includes (DD8) auto-dimming inside rearview mirror. Includes (DD8) auto-dimming inside rearview mirror. Includes (DD8) auto-dimming inside rearview mirror. Not available with (PDA) Texas Edition or (PEB) Custom Sport.
DF2	MIRRORS , outside high-visibility vertical camper-style, Black with manual folding and extension and lower convex spotter glass
8F2	ORNAMENTATION , delete. Deletes decals and nameplates on truck exterior
TGK	PAINT SPECIAL , solid, one color. All normally body colored non-sheet metal parts will be Black. May require extended lead time. Door handles and mirrors will be grain Black. Deletes standard/packaged body side moldings.
9V5	PAINTS , solid, Woodland Green All normally body colored non-sheet metal parts will be Black. May require extended lead time. Door handles and mirrors will be grain Black. Deletes standard/packaged body side moldings. Requires (TGK) Special Paint and (01U) Special Paint.
9W3	PAINTS , solid, Wheatland Yellow. All normally body colored non-sheet metal parts will be Black. May require extended lead time. Door handles and mirrors will be grain Black. Deletes standard/packaged body side moldings. Requires (TGK) Special Paint and (01U) Special Paint.
9W4	PAINTS , solid, Tangier Orange. All normally body colored non-sheet metal parts will be Black. May require extended lead time. Door handles and mirrors will be grain Black. Deletes standard/packaged body side moldings. Requires (TGK) Special Paint and (01U) Special Paint.

OPTIONAL EQUIPMENT & FEATURES

EXTERIOR CONTINUED

<i>TRW</i>	PROVISION FOR CAB ROOF-MOUNTED LAMP/BEACON , provides an instrument panel-mounted switch and electrical wiring tucked beneath the headliner for a body upfitter to connect a body-mounted warning or emergency lamp. Not available with (6C7) Lighting
<i>GU6</i>	REAR AXLE , 3.42 ratio.
<i>SFW</i>	REAR BACKUP ALARM CALIBRATION . This calibration will allow installation of an aftermarket backup alarm. Not available with SEO (8S3) backup alarm.
<i>BS3</i>	REAR BACKUP ALARM , Rear frame mounted 97 decibel back-up alarm. Not available with SEO (SFW) backup alarm calibration.
<i>LVC</i>	REAR VISION CAMERA with dynamic guide lines (see optional equipment illustration section)
<i>V76</i>	RECOVERY HOOKS , front, frame-mounted, black. Standard with 4WD models. Available with 2WD models.
<i>VQK</i>	SPLASH GUARDS, MOLDED - Black.
<i>7X6</i>	SPOTLAMP , Left-hand (see optional equipment illustration section). Includes (GEZ) Ship/Thru to Kerr Industries. Not available with (7X7) left-and right-hand spot lamps. (See wiring diagram section)
<i>7X7</i>	SPOTLAMPS , Left- and right-hand (see optional equipment illustration section). Includes (GEZ) Ship/Thru to Kerr Industries. Not available with (7X6) left-hand spot lamp. (See wiring diagram section)
<i>A91</i>	TAILGATE , Remote locking, Included and only available with (AQQ) Remote Keyless Entry (Standard on 'LS' Model)
<i>4JQ</i>	TIRE , Spare P265/70R17 all terrain blackwall. Replaces the standard blackwall all season spare tire with all terrain tread spare matching road tires. Requires 4WD models and (RC3) P265/70R17BW all terrain tires. Not available with SEO (5Z4) spare wheel, carrier and lock delete
<i>RC3</i>	TIRES , P265/70R17 all-terrain, blackwall (includes spare RC4 all-season blackwall.
<i>RC5</i>	TIRES , LT265/70R17C Light Truck (Load Range C) all-terrain, blackwall. Includes (RHM) spare
<i>9L3</i>	TIRE, SPARE, DELETE , Deletes the spare tire only. Spare wheel and carrier remain. Not available with (RC3) Tires, P265/70R17 all-terrain, blackwall.
<i>R18</i>	TIRES , 265/65R18SL MT 114S blackwall Goodyear Wrangler DuraTrac. Aggressive tread may result in a higher level of noise while driving. Routine tire rotations are strongly recommended. Requires 4WD model and (9G3) Suspension Package, off-road, for base decor vehicles and (PZX) 18" x 8.5" (45.7 cm x 21.6 cm) bright-machined aluminum wheels. Includes (RC4) 17" all-season spare tire.
<i>VQT</i>	TONNEAU COVER , Hard tri-folding with vinyl cover, Requires (UF2) LED Lighting, cargo box.
<i>PZX</i>	WHEELS , 18" x 8.5" (45.7 cm x 21.6 cm) bright-machined aluminum. Requires (R18) 265/65R18SL blackwall tires.
<i>RD6</i>	WHEELS , 17" x 8" (43.2 cm x 20.3 cm) Painted steel. Standard on 1WT, Available on 1LS
<i>SFE</i>	WHEEL LOCKS , Set of 4
<i>5Z4</i>	WHEEL, SPARE , Carrier and lock delete. Deletes the base spare wheel, carrier and lock. Does not delete jack or tools. Requires SEO (9L3) spare tire delete. Not available with (RC3). Tires, P265/70R17 all-terrain, blackwall.
<i>00A</i>	WHEEL, SPARE , Upgrade. Replaces Black standard spare wheel and upgrades to a matching Silver steel road wheel. Includes tire pressure monitoring sensor. Requires (RD6) painted steel wheels. Not available with SEO. (5Z4) spare wheel, carrier and lock delete.
<i>PCR</i>	WT FLEET CONVENIENCE PACKAGE , includes (DL8) outside heated power-adjustable mirrors, (A91) remote locking tailgate and (AQQ) remote keyless entry (available on WT model)

ELECTRICAL

<i>9L7</i>	UPFITTER SWITCHES , 4 switches provide 4-30 amp circuits, (primary battery) to facilitate installation of aftermarket electrical accessories (See wiring diagram section)
<i>6J3</i>	WIRING , For grille lamps and siren speakers (see optional equipment illustration section). Includes (GEZ) Ship/Thru to Kerr Industries. (See wiring diagram section)
<i>6J4</i>	WIRING , For horn and siren circuit (see optional equipment illustration section). Includes (GEZ) Ship/Thru to Kerr Industries. (See wiring diagram section)

OPTIONAL EQUIPMENT & FEATURES

CHASSIS

G80	DIFFERENTIAL , heavy-duty locking rear. Required with (9G3) suspension package
FHS	E85 FLEXFUEL CAPABLE of running on unleaded or up to 85% ethanol.
K05	ENGINE BLOCK HEATER
R9Y	FLEET FREE MAINTENANCE CREDIT . This option code provides a credit in lieu of the free oil changes, tire rotations and inspections (2 maximum), changes during the first 24 months and 24,000 miles period for this ordered vehicle. The invoice will detail the applicable credit. The customer will be responsible for all oil change, tire rotations and inspections costs for this vehicle. Requires one of the following Fleet or Government order types: FBC, FBN, FCA, FCN, FLS, FNR or FGO. Not available with FDR order type.
G06	REAR AXLE , 3.42 ratio.
9G3	SUSPENSION PACKAGE , Off-road, for base decor vehicles, Requires 4WD. Includes Z71 Off Road Suspension components, recovery hooks. Does not include any "Z71" appearance features or (JHD) Hill Descent Control. Requires (G80) heavy-duty automatic locking rear differential, (RC3) P265/70R17 all-terrain, blackwall tires or (R18) 18" Goodyear Wrangler DuraTrac 265/65R18 SL 114S blackwall MT tires with aggressive tire tread or (RC5) LT265/70R17C all-terrain, blackwall tires."
JL1	TRAILER BRAKE CONTROLLER , integrated (requires Z82 trailering package)
Z82	TRAILERING PACKAGE , includes trailer hitch, 7-pin and 4-pin connectors. (Trailer Hitch is Class IV with 11,000 pound capacity)
NQH	TRANSFER CASE , Active, 2-speed electronic Autotrac with dash mounted rotary controls (requires 4WD model)
NZZ	UNDERBODY SHIELD , transfer case protection. Requires 4WD models.
SAM	UNDERBODY SHIELD PACKAGE , Transfer case protection. Available on 2WD models. On 4WD models, not available with (NZZ) underbody shield, transfer case protection.

NOTE: See dealer for additional dealer installed accessories.

DIMENSIONS SSV REGULAR BOX

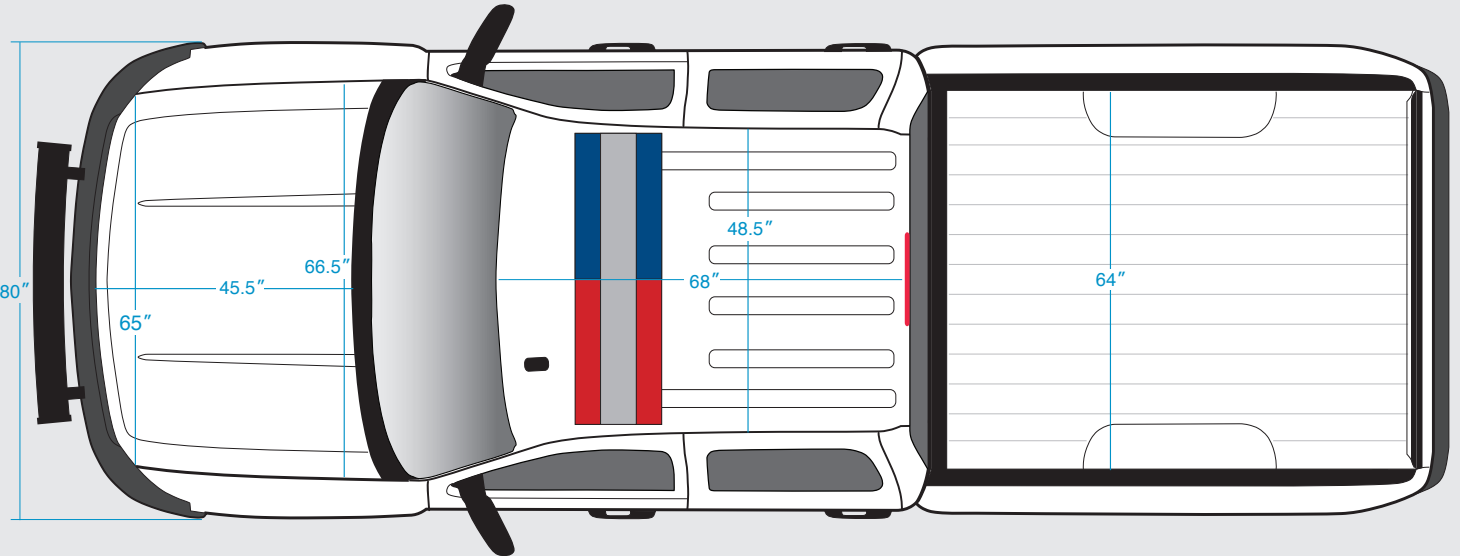
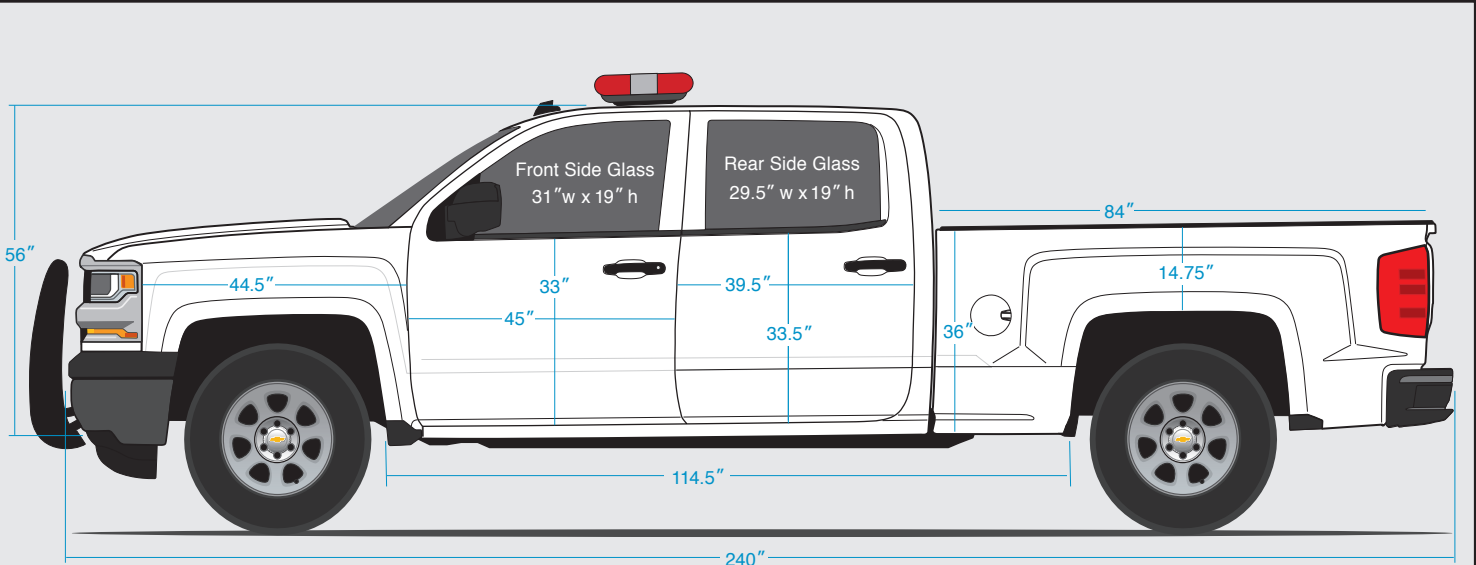

WT Model shown

Estimated material sizes to wrap:

- Hood – 70" x 52"
- Front Doors – 48" x 36"
- Rear Doors – 42" x 36"
- Roof – 72" x 52"
- Tailgate – 64" x 26"



DIMENSIONS SSV SHORT BOX

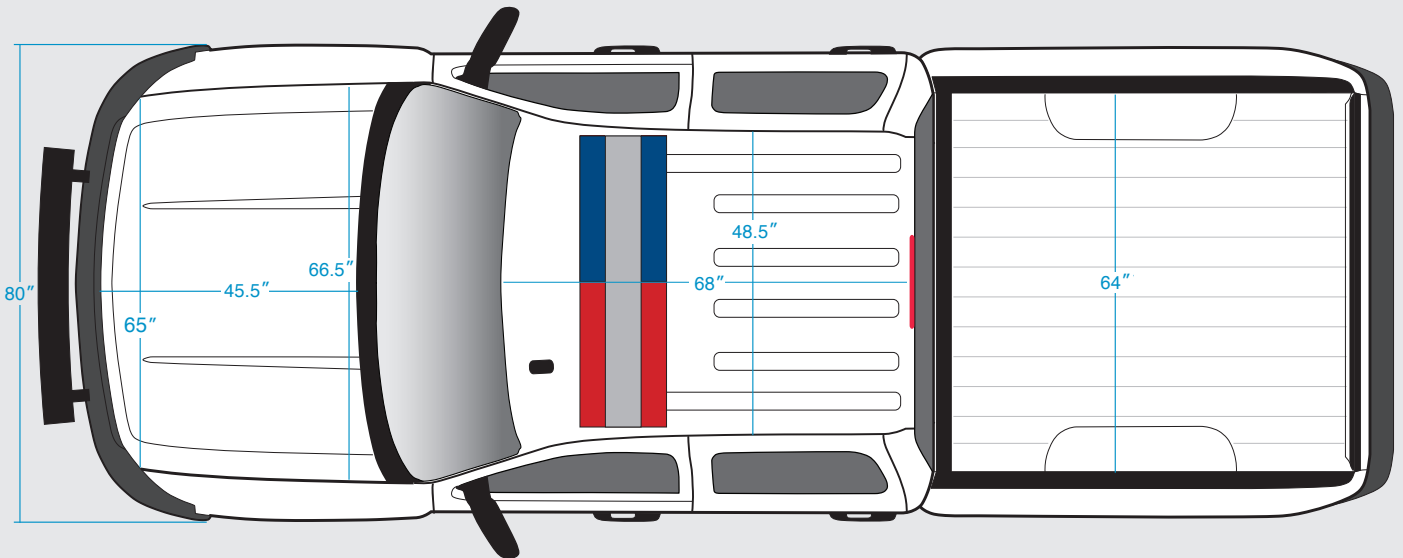
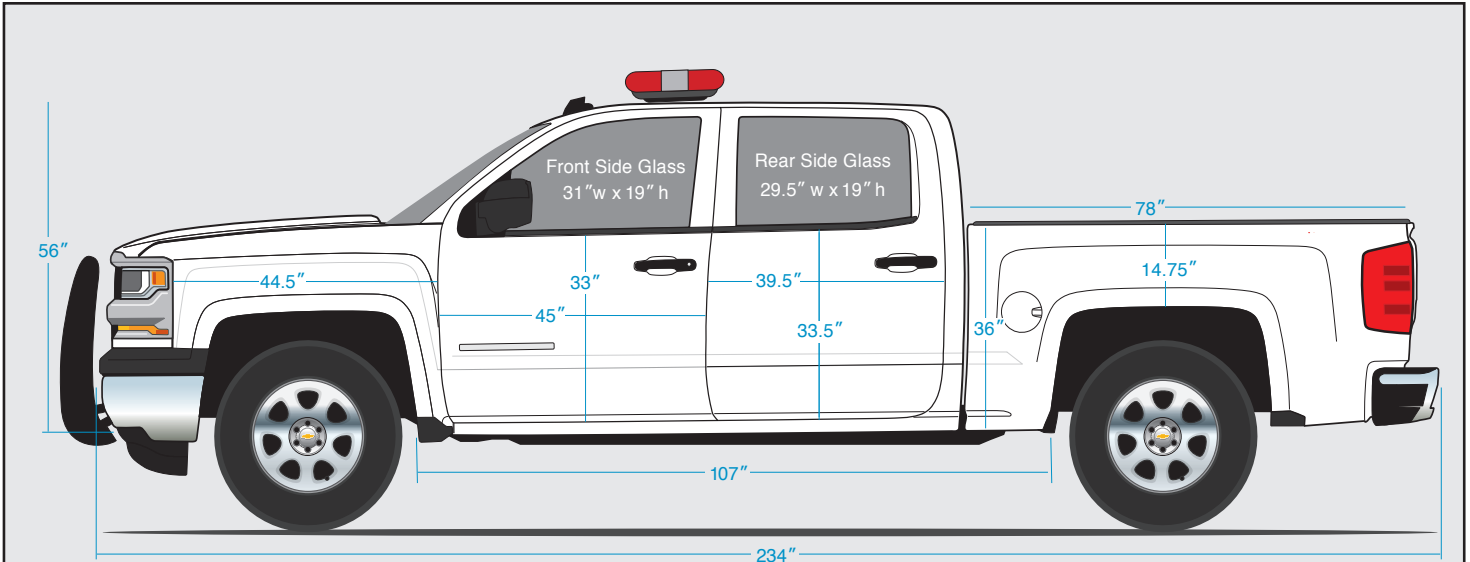

LS Model shown

Estimated material sizes to wrap:

- Hood – 70" x 52"
- Front Doors – 48" x 36"
- Rear Doors – 42" x 36"
- Roof – 72" x 52"
- Tailgate – 64" x 26"



SPECIFICATIONS

GENERAL

Model	CC15543	CK15543	CC15743	CK15743
Drive	2WD Short Box	4WD Short Box	2WD STD Box	4WD STD Box
Cab Style	Crew Cab	Crew Cab	Crew Cab	Crew Cab
Projected top speed with 3.08 axle ⁸	106 mph	112 mph	98 mph	112 mph
Projected top speed with 3.42 axle ⁸	98 mph	112 mph	98 mph	98 mph
Seating capacity	5/6	5/6	5/6	5/6

NOTE: 5 Passenger seating available by ordering 9S1 Center Seat Delete

EXTERIOR (in./mm)

Wheelbase	143.5/3645	143.5/3645	153.0/3886	153.0/3886
Overall length	230.0/5842	230.0/5842	239.57/6085	239.57/6085
Overall width	80.0/2032	80.0/2032	80.0/2032	80.0/2032
Overall height*	74.17/1884	73.97/1879	73.73/1873	73.8/1875
Front bumper to back of cab	150.90/3833	150.90/3833	150.90/3833	150.90/3833
Inside length of box at floor	69.3/1761	69.3/1761	78.87/2003	78.87/2003
Inside width, between wheelhousing, Fleetside	51.03/1296	51.03/1296	51.03/1296	51.03/1296
Turning diameter, curb-to-curb, ft. (m)	TBD	TBD	TBD	TBD
Ground clearance,*	8.7/222	8.9/226	8.5/216	8.9/227

FRONT COMPARTMENT (in./mm)

Head room	42.8/1087	42.8/1087	42.8/1087	42.8/1087
Shoulder room	66.0/1677	66.0/1677	66.0/1677	66.0/1677
Hip room	60.7/1543	60.7/1543	60.7/1543	60.7/1543
Leg room	45.3/1150	45.3/1150	45.3/1150	45.3/1150

REAR COMPARTMENT (in./mm)

Head room	40.5/1029	40.5/1029	40.5/1029	40.5/1029
Shoulder room	65.7/1670	65.7/1670	65.7/1670	65.7/1670
Hip room	60.3/1531	60.3/1531	60.3/1531	60.3/1531
Leg room	40.9/1040	40.9/1040	40.9/1040	40.9/1040

CARGO

Cargo volume ¹ , cargo box, cu. ft./liters	53.4/1,512.3	53.4/1,512.3	61.0/1,727.5	61.0/1,727.5
-------------------------------------------------------	--------------	--------------	--------------	--------------

VEHICLE WEIGHT (lbs./kg.)

Payload ⁵	1810/821	1760/798	1730/785	1710/776
Payload (w/Optional Front Center Seat Delete (9S1/9U3)	1848/838	1798/816	1768/802	1748/793
Base curb weight ⁴	5162/2341	5415/2456	5246/2380	5460/2477
Gross Vehicle Weight Rating ³ (GVWR)	7000/3175	7200/3266	7000/3175	7200/3266
Front Gross Axle Weight Rating (FGAWR)	3850/1746	3950/1792	3850/1746	3950/1792
Rear Gross Axle Weight Rating (RGAWR)	3950/1792	3950/1792	3950/1792	3950/1792

For Max. Trailer Towing see Standard Tires page

PASSENGER COMPARTMENT VOLUME INDEX (cu.ft./liters)

Interior pass. volume	105/2973	105/2973	105/2973	105/2973
Interior cargo	18.6/527	18.6/527	18.6/527	18.6/527

FUEL ECONOMY RATINGS CITY/HIGHWAY/COMBINED

5.3L engine ²	16/23/19	16/22/18	16/23/19	16/22/18
--------------------------	----------	----------	----------	----------

Projected EPA label values, actual mileage will vary with options, driving conditions, driving habits and vehicle's condition.

1. Cargo and load capacity limited by weight and distribution.
2. EPA-estimated MPG.
3. Gross Vehicle Weight Rating (GVWR). When properly equipped, includes vehicle, passengers, cargo and equipment.
4. Vehicle weight in operational status with 100% fuel, fluids to factory fill, and standard base equipment. Does not include driver, passenger or optional content.
5. These maximum payload ratings are intended for comparison purposes only. Before you buy a vehicle or use it to haul people or cargo, carefully review the vehicle loading section of the Owner's Manual and check the carrying capacity of your specific vehicle on the label on the inside of the driver's door jamb.
6. GCWR - Maximum combined weight of truck with passengers plus cargo and trailer with cargo.
7. Adding non dealer accessories or making modifications to the vehicle can affect vehicle performance, aerodynamics, and overall top speed.
- *Published dimensions indicated are at Base Curb Weight.

SPECIFICATIONS

ENGINE

	STANDARD
Type	EcoTec3 V8
Displacement: liters/cu. in.	5.3/325
Horsepower/rpm	355 @ 5600
Torque lb.-ft./rpm	383 @ 4100
Induction system	Direct Injection
Compression ratio	11.0:1
Exhaust	Single
Minimum recommended fuel octane	87
Fuel capacity, approximate, gallon/liters	26/98
Oil with filter (quarts/liters)	8.5/8
Cooling capacity (quarts/liters)	17.4/16.5

TRANSMISSION

Automatic electronic with overdrive	6 Speed
Fuel pan removed and filter replaced (quarts/liters)	6.0/5.7

AXLE

Ratio	3.08
-------	------

BRAKES

ABS with vacuum-boost	Disc/Disc
Front-swept area (sq. in./sq. cm)	250/1612
Rear-swept area (sq. in./sq. cm)	252/1628
Total front and rear swept area (sq. in./sq. cm)	504.6/3255
Front rotor diameter (in./mm)	13.0/330
Rear rotor diameter (in./mm)	13.5/345
Front rotor thickness (in./mm)	1.2/30
Rear rotor thickness (in./mm)	.79/20

TIRES

Type	All Season, Blackwall
Size	P255/70R17

WHEELS

Type	Steel
Size	17"x 8"

CHASSIS

Frame	Full perimeter steel
Front suspension	Coil over shock and stabilizer bar
Rear suspension	Multi-link, coil springs
Steering type	Rack and pinion
Steering ratio	16.3:1

BATTERIES

	PRIMARY	AUXILIARY
Type	Maintenance free	Maintenance free
BCI group size	LN4	LN3
Volts	12	12
Amp hour rating	80	70
Cold cranking-amps @ 0°F (-18°C)	720	730

ALTERNATOR

Type	Denso SC3
Amps	77°F (25°C) 170

SILVERADO SSV ALTERNATOR OUTPUT

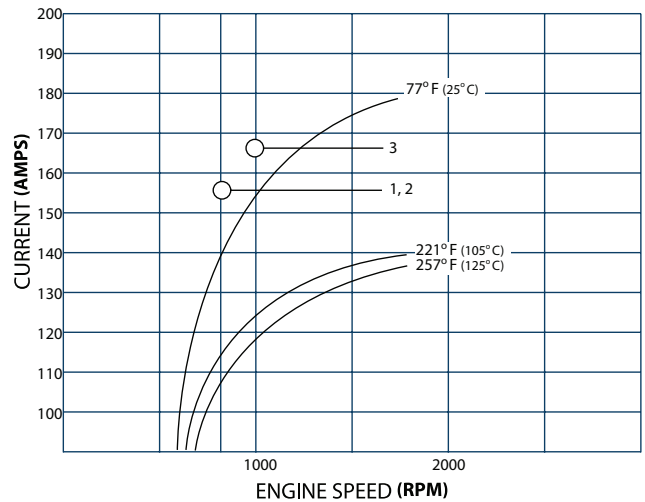

BOOST LEVEL

	PARK/NEUTRAL	DRIVE
Normal Idle	550	500
1	800	650
2	800	725
3	1000	800

STANDARD EQUIPMENT

SURVEILLANCE FEATURE MANUAL LAMP CONTROL AND 9G8

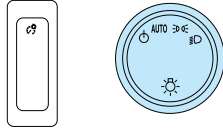

The headlamp control on the driver's side of the instrument panel operates the exterior lamps. If your Silverado does not have option 9G8, DELETE DAYTIME RUNNING LAMPS and AUTOMATIC HEADLAMPS, the Daytime Running Lamps and Automatic Headlamps can be turned OFF for one ignition cycle by rotating the headlamp control knob momentarily counter-clockwise. See your Silverado Owner's Manual.

Surveillance Feature (available mid-model year) The Body Control Module (BCM) will be calibrated to provide disabling of the exterior and interior automatic lighting. The BCM is located under the instrument panel to the left side of the steering column.

The Surveillance Feature can be connected by installing a terminated wire in cavity 5 of the Light Pink colored BCM connector, X6. The wire and terminal part number to be installed is GM #13582297. When a customer-provided terminated wire is properly installed in X6-5 and the wire is connected via a customer-provided switch to vehicle ground, automatically controlled lighting is disabled or dimmed to minimum Federally regulated level.

Option SEO 9G8 – Delete Daytime Running Lamps and Automatic Headlamps. This option disables the Daytime Running Lamps and Automatic Headlamps control feature. Exterior lamps are only manually controlled (Option 9G8 is not available in Canada).

When the headlamp switch is in Auto with 9G8 installed, the instrument cluster, radio display and air conditioning illumination remains at daytime intensity and are dimmable only when the headlamp switch is rotated to the Parking Lamps or Headlamps positions. If SEO 9G8 is not installed, the displays are dimmable with the Headlamp switch in the AUTO position. The instrument cluster, radio and AC displays will dim if the Surveillance Feature is activated as described above.

Interior courtesy lamps, including dome lamps, can be turned OFF with a three-position switch located in the front overhead console. The interior lamp control positions are: OFF – DOOR – ON

When the switch is in the OFF position, all interior lighting remains off whenever the doors are opened.

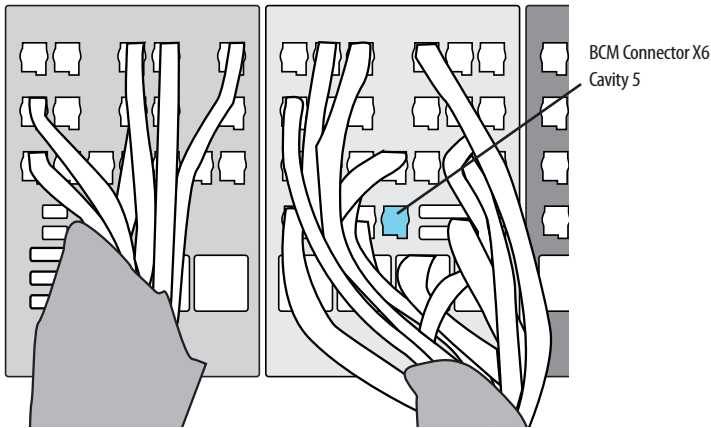

TIRE PRESSURE MONITOR

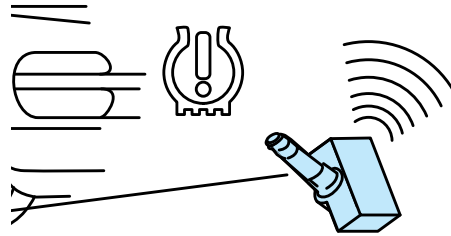

The Silverado 1500 Special Service 5W4 Crew Cab Package is equipped with Tire Pressure Monitor System (TPMS) which warns of low tire pressure. The Tahoe Police Package has a full size spare tire with a TPMS sensor which does not read spare tire pressure. When the spare tire from your vehicle or an unused spare tire from another Police Package is placed in use as a road wheel, the system will not read the presence of the new TPM sensor and must be calibrated. Refer to your owner's manual for additional information the Tire Pressure Monitor System Programming.

SERVICE PARTS IDENTIFICATION LABEL

SERVICE PARTS IDENTIFICATION										DO NOT REMOVE		
1GNLC2E0BR8152140										PDBJCH	CC10706	
AGK	AG2	AL0	AMF	AP3	AR9	AT8	AXJ	AY0	A75	A76		
BDR	B3B	B42	B86	B9V	C67	DK2	EF7	E2C	FE9	FR9		
IPG	JA9	JL9	KD1	KG4	LGD	MX0	M15	NK5	NT7	N99		
OST	QPP	R7V	R8N	R9Z	SLM	T53	UH8	UJM	UN9	UT7		
UW6	UIC	U77	V77	V8D	WL9	ZFH	1S2	19C	41U	191		
3FL	6A3	6E2	6HP	6J1	6J3	6J4	6J7	7B3	7HP	7M9		
7X6	8MZ	PPV	9MZ									
BC/CC			U 636R									

A Service Parts Identification (SPID) Label provides Vehicle Identification Number (VIN)-specific Option Code content list, Engineering Model Number (Nameplate, body style), Exterior paint system, Exterior paint color code and Interior trim level and color.

AERO SHUTTERS



Aero shutters are designed to close when operating conditions permit. The shutters are located on the front of the A/C condenser under hood to divert airflow around the front of the truck reducing wind drag and improves fuel economy. When the cooling system requires more air flow the shutters automatically reopen, ensuring proper air flow through the radiator.

STANDARD EQUIPMENT

WIRING PROVISIONS

The vehicle has standard and may have optional wiring provisions for connecting 12 volt battery power to customer installed equipment.

STANDARD

The standard upfitter provisions are terminated in the Instrument panel Electrical Center (ICEM) connector X7. The ICEM is located in the lower instrument panel to the left of the brake pedal assembly. The following circuits are terminated in ICEM connector X7.

Terminal 8 - Battery power, hot in ignition RUN/ACCECESSORY

Terminal 11 - Battery power, hot in ignition RUN/CRANK

Terminals 7 and 17 - Primary battery power.

Maximum load for each circuit must not exceed 15 amps.

Terminal 10 - Ground

Terminal 19 - Vehicle Speed Signal (VSS) provides 4000 pulses per mile

The vehicle Electronic Brake Control Module (EBCM) VSS output circuitry does not include a logic pull-up resistance. If a pull-up resistance is not part of the customer equipment VSS input connection circuitry, a 5000 ohm resistor can be connected between the vehicle VSS circuit wire and vehicle battery power.

A 12 volt auxiliary battery is included a standard equipment and is located at the left front of the engine compartment. Customer connection to the auxiliary battery must be made at the fuse assembly located on the battery positive post.

OPTIONAL 9L7 UPFITTER SWITCHES

Four 12 volt, 30 amp, relay controlled battery power circuits may be present in the vehicle. The relays are operated via instrument panel switches located on the lower center instrument panel, below the heating and air conditioning controls. The following relay load circuits are terminated in ICEM connector X7 as listed.

Terminal 20 - Controlled by instrument panel Switch 1

Terminal 14 - Controlled by instrument panel Switch 2.

Terminal 4 - Controlled by instrument panel Switch 3

Terminal 1 - Controlled by instrument panel Switch 4

Connection to the circuits located in ICEM X7 must be made by a customer-provided jumper harness consisting of a connector and appropriately sized wires. The mating connector for ICEM cavity X7 is GM service part 19328970 (OEM 19324036). Refer to the wiring diagrams in this Specification for more information and to GM Upfitter Bulletin 115. A complete harness for connection to ICEM X7 is available from the GM police vehicle Second Stage Manufacturer, Kerr Industries (905 725 6561).

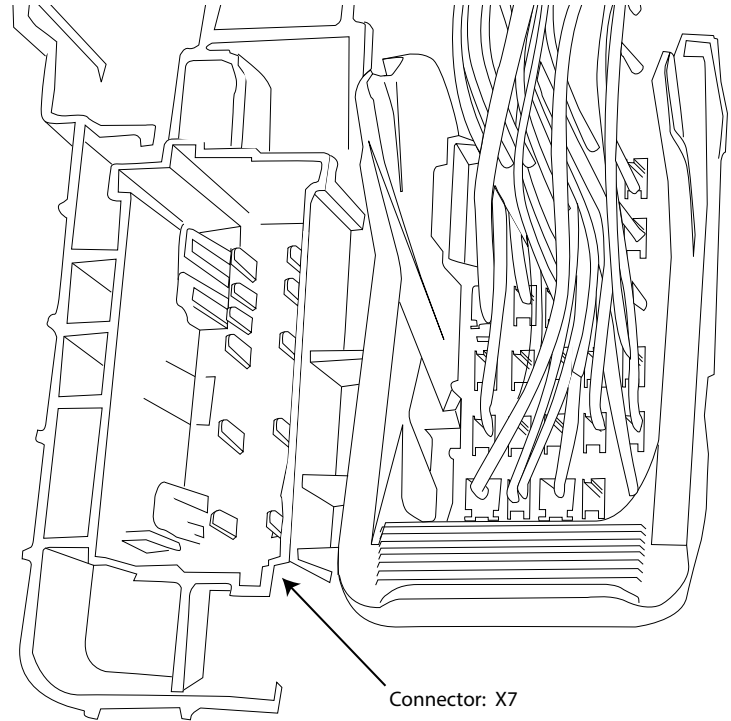

OPTIONAL EQUIPMENT

6J3

WIRING PROVISIONS FOR VEHICLE GRILLE LAMPS AND SPEAKER/SIREN

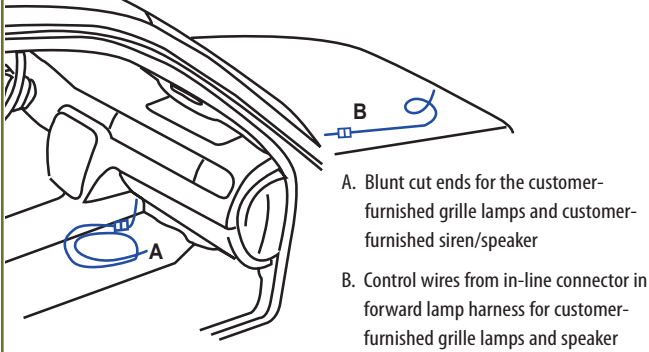

The SEO 6J3 wiring provision has a 5-foot (1.5 m) harness coiled underneath the instrument panel on the passenger side. The wiring circuits are routed from under the instrument panel to a 1-foot (30 cm) coil secured in the area behind the grille. There are four 16-gauge (1.0 mm²) wires for connecting to the grille lamps (GRY, TAN) and siren speaker (LT BU, LT GN)

The SEO 6J3 wiring provision also includes one 18-gauge (0.8 mm²) control wire for the SEO 6J7 Exterior Lamps Emergency Flashing System.

When Option 6J7 is installed without Option 6J3, only the green control wire and the blue/green Separation of Function wires are provided for customer furnished switching to operate the Emergency Flashing System.

Note: For wiring diagram see *Wiring Section*

6J4

WIRING PROVISION FOR HORN SIREN CIRCUIT

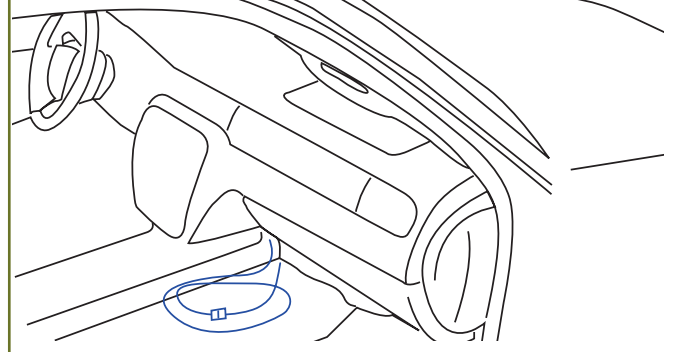

This provision permits customer connection of a switch to select either horn of siren operation when the horn pad is pressed.

A 22-gauge (0.35 mm²) wire is connected to an in-line connector in the horn circuit of the instrument panel harness under the instrument panel. The end of this harness extension is a 5-foot (1.5 m) loop of wire coiled under the center of the instrument panel. **NOTE:** For wiring diagram see *Wiring Section*

7X6

SPOTLAMPS

7X7

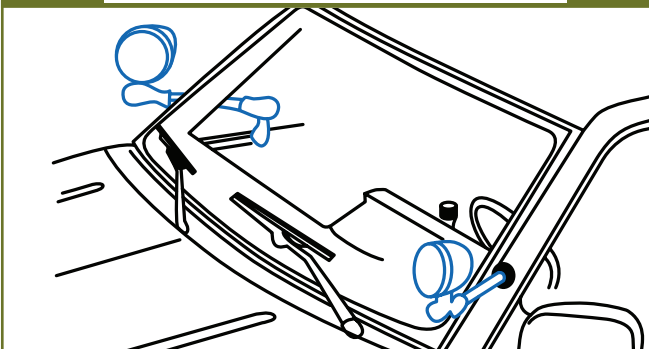

7X6 Spotlamp left hand, pillar-mounted unity, 6-inch with replaceable H3 halogen bulb; independently fused

7X7 Spotlamps left and right hand, pillar-mounted unity, 6-inch with replaceable H3 halogen bulb; independently fused

NOTE: • Lamp bulbs are halogen 12 volt 100 watt H-3 rated at 245,000 candle power

- For fuse location see *Wiring Section*
- Factory installation of spotlamps is recommended. Special tooling is used to locate and drill the spotlamp shaft hole in the windshield pillars. Field installation of spotlamps must not interfere with proper deployment of the roof rail airbag in the event of a crash.
- Customer furnished spotlamp assembly must be installed to avoid interference with proper deployment of roof rail and passenger side airbags

UVC

REAR VISION CAMERA

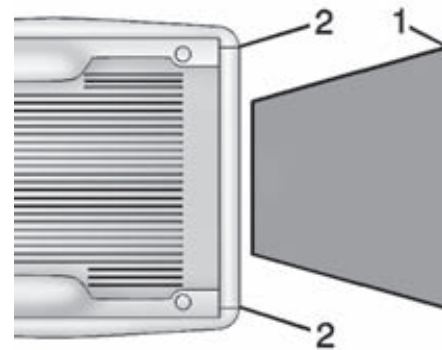

1. View Displayed by the Camera in Radio Screen
2. Corners of the Rear Bumper

Displayed images may be farther or closer than they appear. The area displayed is limited and objects that are close to either corner of the bumper or under the bumper do not display.

When the vehicle is shifted into R (Reverse), the RVC displays an image of the area behind the vehicle in the center stack display. The previous screen displays when the vehicle is shifted out of R (Reverse) after a short delay. To return to the previous screen sooner, press a button on the infotainment system, shift into P (Park), or reach a vehicle speed of 8 km/h (5 mph).

NOTE: The Rear Vision Camera will not work properly if the tailgate is down. If the tailgate is down, do not use this systems.

OPTIONAL EQUIPMENT

DF2

CAMPER-STYLE MIRRORS

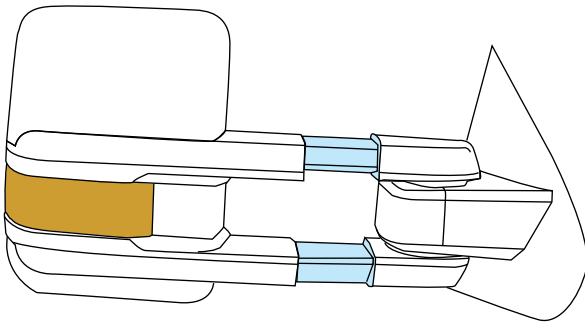
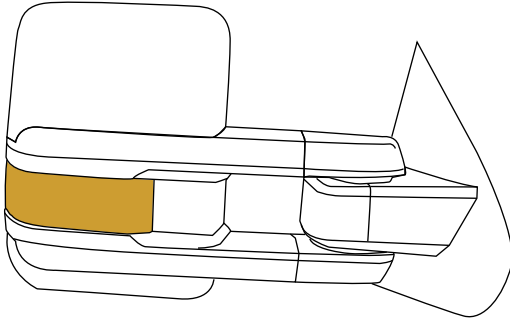

Extra-large high-visibility vertical camper-style mirrors, manual extending with integrated turn signals and lower convex spotter glass.

VQK

SPLASH GUARDS, MOLDED

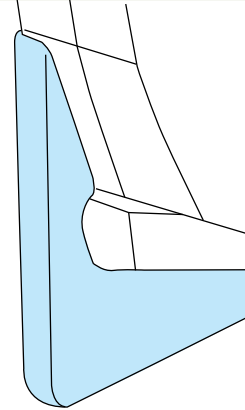

Black finish

NQH

AUTOMATIC TRANSFER CASE

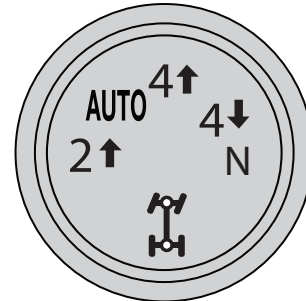

Active, 2-speed electronic Autotrac with rotary controls, includes neutral position for dingy towing. Use the transfer case knob next to the steering wheel to shift into and out of four-wheel drive.

VBJ

REAR UNDERSEAT STORAGE

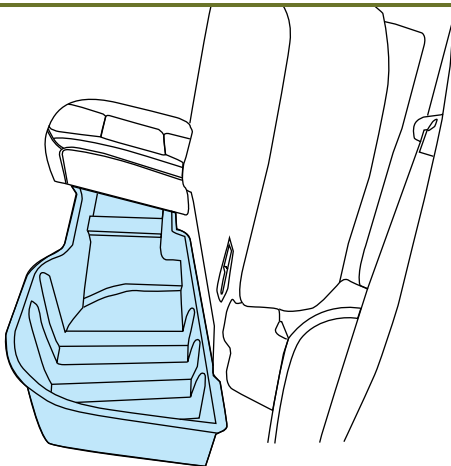

Composite storage bin

WIRING

STANDARD - WIRING PROVISIONS FOR IGNITION POWER AND SIGNAL CIRCUITS

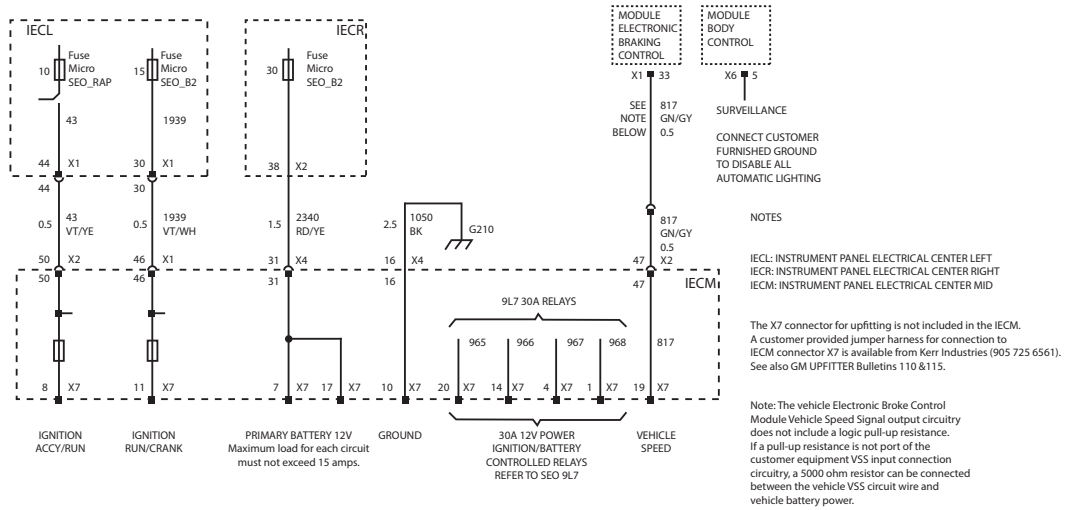

OPTIONAL - 9L7 UPFITTER SWITCHES FOR RELAY CONTROLLED 12 VOLT POWER

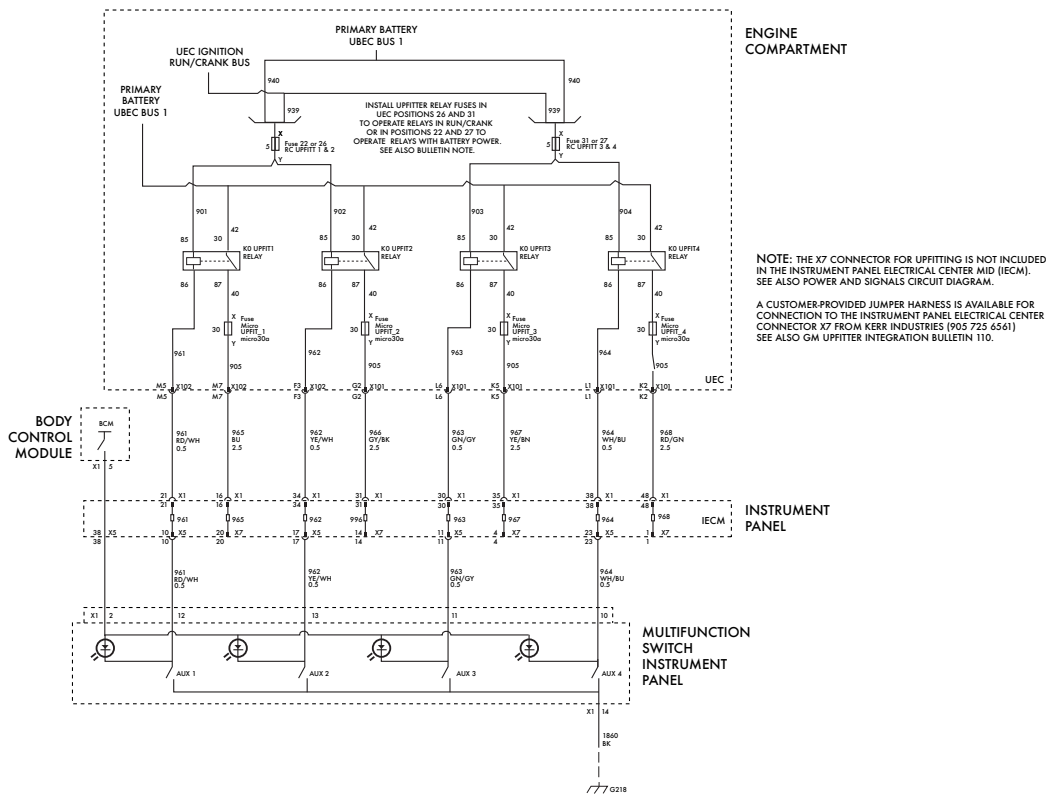

WIRING

WIRING PROVISIONS FOR GRILLE LAMPS AND SPEAKER/SIREN

WIRING PROVISION FOR GRILLE LAMPS AND SPEAKER/SIREN
OPTION 6J3

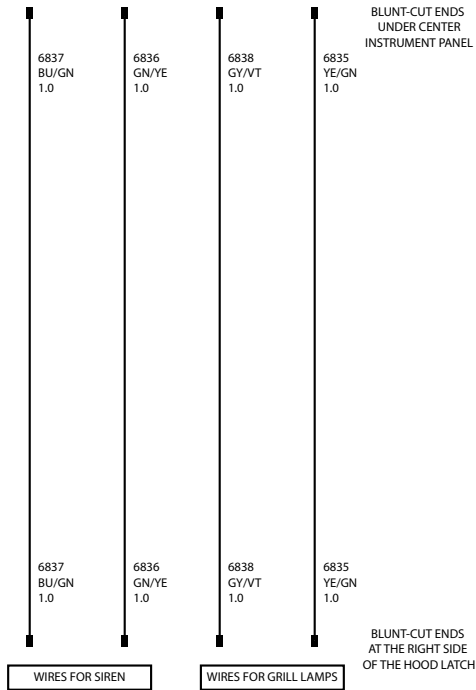

WINDSHIELD PILLAR MOUNTED SPOTLAMPS

WINDSHIELD PILLAR-MOUNTED SPOTLAMPS
OPTION 7X6 LH ONLY / OPTION 7X7 LH AND RH

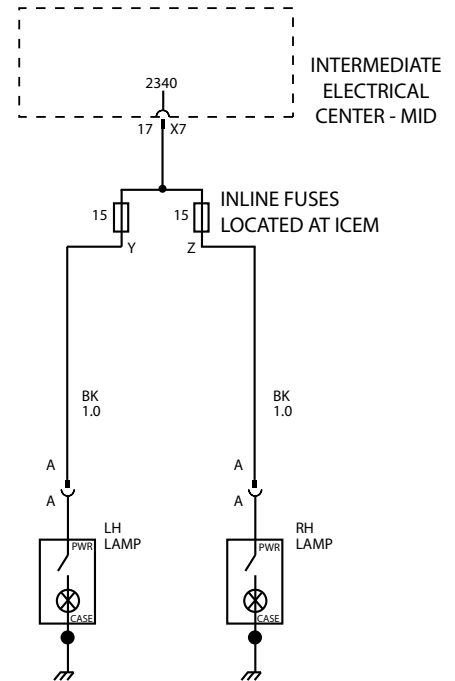

LAMP BULBS - HALOGEN H7635

WIRING PROVISION FOR HORN-SIREN CIRCUIT

WIRING PROVISION FOR HORN-SIREN CIRCUIT
OPTION 6J4

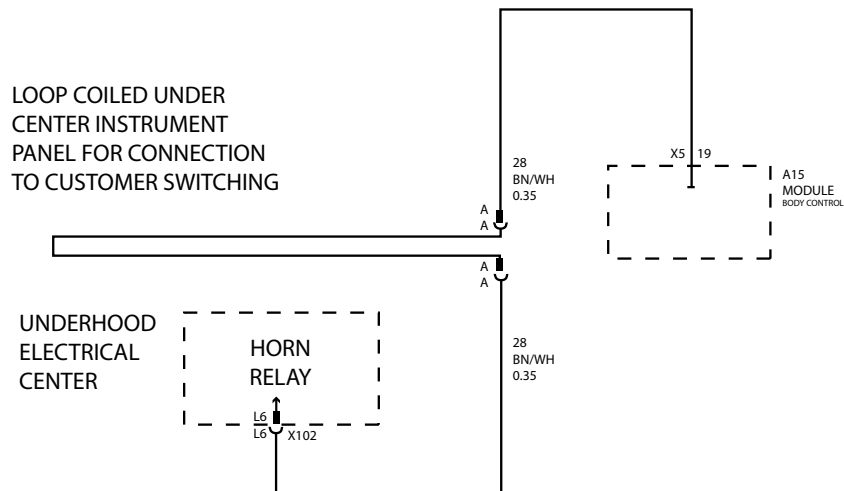

TOP VIEW OF INSTRUMENT PANEL AND APPROXIMATE DEPLOYMENT AREA OF THE AIRBAG ZONE

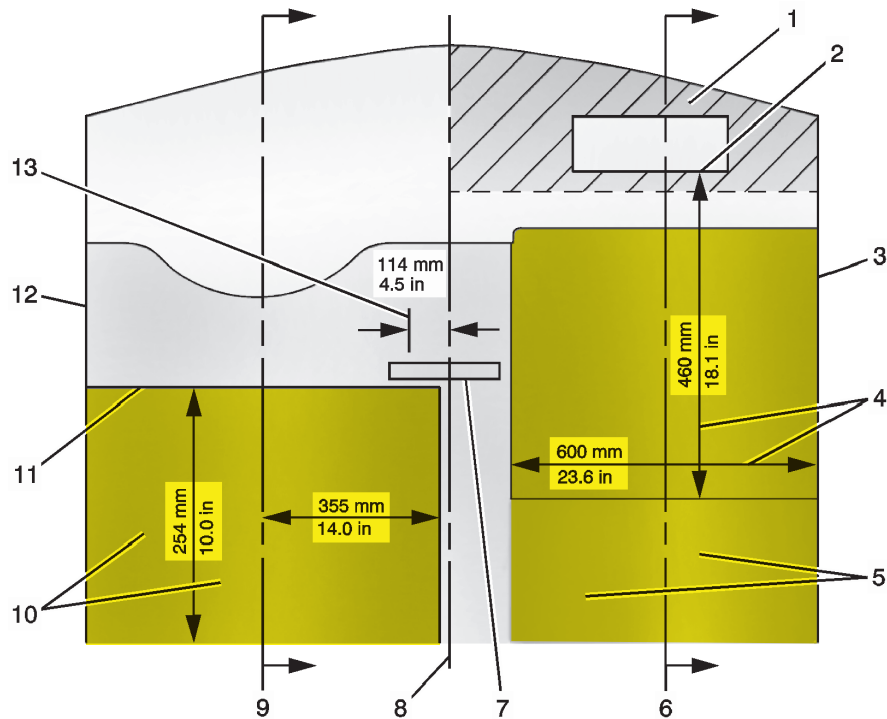

1. Passenger Side Instrument Panel Top Surface Zone
2. Passenger Frontal Airbag Module Trim Panel – Rear Edge
3. Passenger Side Door
4. Approximate Dimensions of Inflated Airbag
5. Passenger Frontal Airbag Deployment Zone
6. Passenger Centerline
7. Inside Rearview Mirror
8. Vehicle Centerline
9. Driver Centerline
10. Driver Frontal Airbag Deployment Zone
11. Front of Steering Wheel
12. Driver Side Door
13. Shift Selector Arc

Airbag inflation can cause severe injury or death to anyone too close to the bag when it deploys. Be sure every occupant is properly restrained.

SIDE VIEW OF DRIVER FRONTAL AIRBAG DEPLOYMENT ZONE

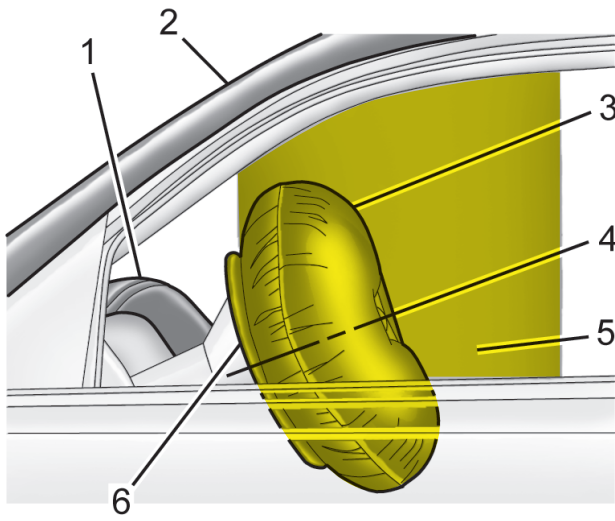

1. Top of Instrument Panel
2. Top Edge of Windshield
3. Inflated Airbag – Steering Wheel
4. Centerline of Steering Column at Mid-Tilt
5. Driver Frontal Airbag Deployment Zone
6. Front of Steering Wheel

SIDE VIEW OF PASSENGER FRONTAL AIRBAG DEPLOYMENT ZONE

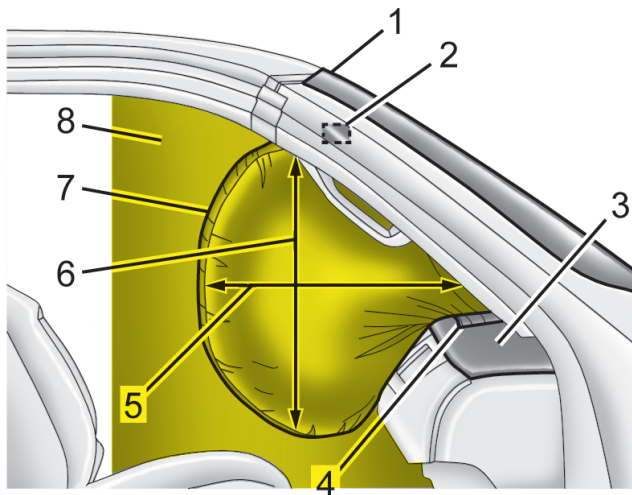

1. Top Edge of Windshield
2. Inside Rearview Mirror
3. Instrument Panel Top Surface Zone
4. Passenger Frontal Airbag Module Trim Panel – Rear Edge
5. Inflated Airbag – Horizontal Dimension, approximately 18.1 in (460 mm)
6. Inflated Airbag – Vertical Dimension (from Top of Occupant's Lap to Headliner)
7. Inflated Airbag – Instrument Panel
8. Passenger Frontal Airbag Deployment Zone

Airbag inflation can cause severe injury or death to anyone too close to the bag when it deploys. Be sure every occupant is properly restrained.

ROOF-RAIL AND SEAT-MOUNTED SIDE IMPACT AIRBAG DEPLOYMENT ZONES - PASSENGER SIDE SHOWN, DRIVER SIDE SIMILAR

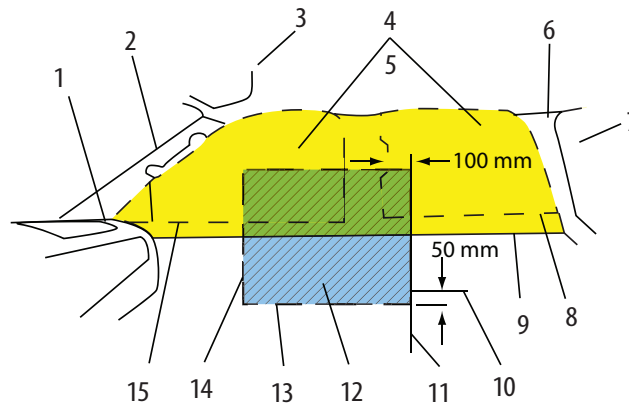

- | | |
|---------------------------------------------------------------------------------------------------------------------------------------------------------------------------------------------------------------------------------------------------------------------------------------------------------------------------------------------------------------------------------------------------------------------------------------------------------------------------------------------------------------|-------------------------------------------------------------------------------------------------------------------------------------------------------------------------------------------------------------------------------------------------------------------------------------------------------------------------------------------------------------------------------------------------------------------------------------------------------------------------------------------------------------------------------------------------------------|
| <ol style="list-style-type: none"> 1. Front of Deployment Zone at Bottom of Windshield Pillar Trim 2. A-Pillar Trim with Grab Handle (Passenger Side) 3. Sun Visor 4. Deployment Zone - Seat Rows 1 and 2 and Cargo Area 5. Top of Deployment Zone - Along Roof-rail at Edge of Headliner 6. C-Pillar Upper Trim 7. Rear Window 8. Top Edge of Rear Door Trim 9. Bottom of Deployment Zone at Top of Side Door Armrest | <ol style="list-style-type: none"> 10. Top Surface of Front Seat Cushion (with Seal Fully Lowered) 11. Seat-Mounted Side Impact Airbag Deployment Zone (3.9 in/100mm to Rearward of Back Edge of B-Pillar Trim Grab Handle) 12. Lower Part of Front Seat Deployment Zone (With Seat Fully Lowered) 13. Bottom of Seat-Mounted Side Impact Airbag Zone (2.0in/50mm Below Top of Seat Cushion with Seat Fully Lowered) 14. Rear of Front Door Trim Armrest Handle 15. Top Edge of Front Door Trim |
|---------------------------------------------------------------------------------------------------------------------------------------------------------------------------------------------------------------------------------------------------------------------------------------------------------------------------------------------------------------------------------------------------------------------------------------------------------------------------------------------------------------|-------------------------------------------------------------------------------------------------------------------------------------------------------------------------------------------------------------------------------------------------------------------------------------------------------------------------------------------------------------------------------------------------------------------------------------------------------------------------------------------------------------------------------------------------------------|

ROOF-RAIL AND SEAT-MOUNTED SIDE IMPACT AIRBAG DRIVER AND PASSENGER DEPLOYMENT ZONES - VIEW FROM REAR CARGO AREA

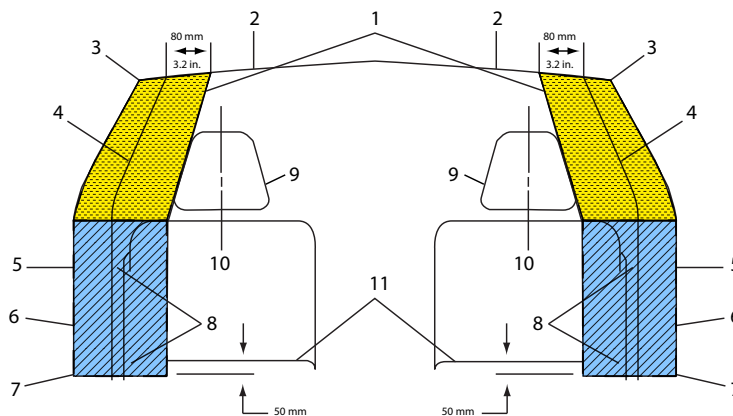

- | | |
|---------------------------------------------------------------------------------------------------------------------------------------------------------------------------------------------------------------------------------------------------------------------------------------------------------------------------------------------------------------------------------------------------------------------------------------------|-------------------------------------------------------------------------------------------------------------------------------------------------------------------------------------------------------------------------------------------------------------------------------------------------------------------------------------------------------------------------------------------------------------------------|
| <ol style="list-style-type: none"> 1. Roof-rail Airbag Deployment Zone 2. Underside of Headliner 3. Edge of Headliner 4. Inner Center and Rear Pillar Trim 5. Inner Front and Rear Door 6. Side Door Upper Armrests and Rear Quarter Trim Armrests 7. Bottom of seat-mounted side impact airbag zone (2.0 in/50 mm) below top of seat cushion with seat fully lowered. | <ol style="list-style-type: none"> 8. Front Seatback Side Deployment Zone 9. Front Seat Head Restraint 10. Seat Centerline 11. Top of Seat Cushion <p>The driver and passenger seat-mounted side impact airbag deployment zones move up, down, fore, aft, as the seat is adjusted by the occupant. The deployment zones also move as the seatback is reclined and raised.</p> |
|---------------------------------------------------------------------------------------------------------------------------------------------------------------------------------------------------------------------------------------------------------------------------------------------------------------------------------------------------------------------------------------------------------------------------------------------|-------------------------------------------------------------------------------------------------------------------------------------------------------------------------------------------------------------------------------------------------------------------------------------------------------------------------------------------------------------------------------------------------------------------------|

Airbag inflation can cause severe injury or death to anyone too close to the bag when it deploys. Be sure every occupant is properly restrained.

AIRBAGS & STABILITRAK

AIRBAG FAQ

Can specialty vehicle equipment (e.g. radar devices, video cameras, computers, meters, radio trees, shotguns, etc.) still be mounted in cars with passenger side airbags?

Yes, but care must be taken to mount the equipment outside of the deployment zone. Airbags inflate with great force and will interact with any object in the deployment zone. Therefore, to reduce the risk of injury to vehicle occupants, GM recommends that the air deployment zone be kept free of any equipment. If a piece of equipment were to become dislodged it could strike an occupant in the vehicle and result in injury. The likelihood of an object becoming dislodged is influenced by many factors, including the proximity of the object to the inflatable restraint, the size and shape of the object, and the means by which the object is secured to the vehicle. In addition to these factors, the trajectory and velocity of a dislodged object can be influenced by the type and severity of vehicle crash.

Objects that are in the deployment zone, but do not become dislodged by an inflating airbag can still affect the performance of the airbag. For example, such objects could tear the fabric or affect the shape of the airbag, thus reducing the ability of the bag to provide restraint.

Is it possible to shield equipment that is installed in the passenger side frontal airbag deployment zone in a manner that will allow full and safe airbag deployment?

Due to the complexity of influencing variables, GM is unable to evaluate the potential for shielding expected equipment configurations in all accident scenarios in order to assure that the airbag performance would be unaffected. While shielding may protect certain equipment from being damaged or dislodged, it may also negatively affect the inflation characteristics of the airbag. The airbag's shape, inflation angle, fold pattern, and inflation rate and pressure are developed to maximize the protection capability of the inflatable restraint system. Therefore, GM cannot recommend the placement of any equipment in the deployment zone, even if it is shielded to protect it from damage.

Front airbag systems and instrument panel mounted equipment.

Passenger airbags in GM vehicles deploy in different ways depending upon the type of vehicle and the particular instrument panel design.

In some vehicles, the passenger airbag deploys through a discrete door located on the top surface of the instrument panel (top-mount airbag systems). In other vehicles, the passenger airbag deploys through a discrete door mounted on the vertical rearward surface of the instrument panel, above the glove box door (mid-mount airbag system). With these types of top mount and mid-mount passenger airbag systems, the top pad of the instrument panel remains in place during deployment.

Some GM passenger airbag systems deploy from beneath the instrument panel top pad. These are considered 3/4-mount airbag systems with a "deployable top pad." The entire instrument panel top pad is the "deployment door" from under which the inflating airbag emerges. When an airbag deployment is commanded, the forces from the inflating passenger airbag push up on the instrument panel top pad, releasing special fasteners across the rearward edge of the top pad. This allows the top pad to rotate upward so that the passenger airbag may emerge. The top pad rotates upward to open widest at the right hand side, and is usually forced upward into contact with the windshield on the right hand side of the vehicle during a deployment.

Instrument panel top mounted special equipment, such as a radar antenna and control unit or video camera must be positioned to the left of the vehicle center line. This equipment must be mounted as low as possible and securely fastened to the top pad to avoid being dislodged in the event of a crash and possible

airbag deployment. In the process of securely fastening special equipment to the top, DO NOT fasten down the top pad itself to any other vehicle component such as the cluster trim plate. As described above, the top pad rotates upward during a deployment. In order to enable the proper deployment of the passenger airbag, specialty equipment installation MUST NOT PREVENT the top pad from rotating upward during deployment. Location and attachment of special equipment should minimize added resistance or interference to upward rotation of the top pad during deployment.

On the right half of the top pad closest to the passenger airbag module, GM recommends that no equipment be mounted. When mounting equipment on the driver side of the top pad, GM recommends that the total mass of the top pad mounted special equipment not exceed 8 pounds (3.6 kilograms), since some top pads tend to rotate about the left end.

Fasteners used to secure special equipment to the instrument panel top pad, the windshield glass, or to the windshield upper frame (header), should be selected to ensure that these devices will remain attached during a vehicle crash and possible airbag deployment.

Side-Impact Airbags for crashes to the vehicle sides.

The airbag system in your police vehicle includes roof rail mounted Head Curtain side airbags. The vehicle is also equipped with seat back mounted upper body airbags located on the outboard side of the driver and front passenger seat backs. Together the Head Curtain and seat-mounted side airbags are intended to protect the head and upper body in the event of a side crash. The Head Curtain and seat-mounted side airbags also may be commanded to deploy in the event that the vehicle sensing system detects an impending or underway rollover of the vehicle. Some vehicles may also be equipped with an optional airbag, mounted on the inboard side of the driver seat back.

Can Specialty Vehicle Security Barriers be mounted within the side airbag deployment zones?

No. The side airbags inflate extremely fast because of the nature of side crashes to the vehicle. Mounting a security barrier behind the front seats with the ends placed within the side airbag deployment zones will result in unintended interaction between the barrier and the inflating side airbags. To reduce the risk of injury to the vehicle occupants, GM recommends that the side airbag zones be kept free of any customer installed equipment.

Customer furnished equipment installed to the vehicle roof.

The roof system may also include side airbag head curtain components. Inflation devices and cushion components may be mounted on the vehicle roof side from the base of the windshield along the roof rail above the door openings to the base of the rear window pillar. Care must be taken to avoid damage to these components or interference with their operation when installing roof mounted equipment such as emergency lamps and communication antennas.

AIRBAG FAQ

Can the installation of push bumpers on the front end of the vehicle affect the deployment of the airbag?

General Motors is not aware of adverse effects during crash events from the many push bumpers that have been installed on GM police vehicles. Because there are many styles of push bumpers available with varying crash characteristics, installation of push bumpers may or may not affect deployment timing of the airbags. Push bumpers should be mounted to avoid modifying the vehicle structure and interfering with the front airbag sensors mounted on the upper radiator support cross member.

Two front impact sensors are installed in General Motors vehicles. Do not relocate or disconnect the front sensors. The location and orientation of the front sensors are critical for correct operation of the airbag system. Avoid mounting components on or near the sensors. Push bumper styles with vertical pushing members that are in foreaft alignment with the front airbag sensors are not recommended.

When should an airbag inflate?

The driver's and right-front passenger's frontal airbags are designed to inflate in moderate to severe frontal or near-frontal crashes. But they are designed to inflate only if the impact speed is above the system's designed "threshold level."

In addition, your vehicle has "dual stage" frontal airbags which tailor the amount of restraint according to crash severity. For moderate frontal impacts, the airbags inflate at a level less than full deployment. For more severe frontal impacts, "dual stage" frontal airbags deploy at full levels.

If the front of your vehicle goes straight into a wall that doesn't move or deform, the threshold level of the reduced deployment is about 12 to 16mph (19 to 15 km/h), and the threshold level for a full deployment is about 18 to 24 mph (29 to 28.5 km/h). The threshold level can vary, however, with specific vehicle design, so that it can be somewhat above or below this range.

If your vehicle strikes something that will move or deform such as a parked car, the threshold level will be higher. The driver's and right-front passenger's frontal airbags are not designed to inflate in rollover, side impacts, or rear impacts, because inflation would not help the occupant.

Seat mounted side impact airbags are designed to inflate in moderate to severe side crashes. The side impact airbags will inflate if the crash severity is above the designed "threshold level." The threshold level can vary with specific vehicles design. The side impact airbags are not designed to inflate on frontal or near-frontal impacts or rear impacts, because inflation would not help the occupant.

Roof rail mounted head-curtain airbags are designed to inflate in moderate to severe side crashes. In addition, certain vehicles have head-curtain airbags which are also designed to inflate in situations where an impending rollover condition is identified by the vehicle's rollover sensing system and/or frontal or near-frontal impacts if the crash severity is above the designed "threshold level."

Safety belt pretensioners at the driver and front passenger seat positions are designed to deploy in frontal, near-frontal, side, and rear crashes that exceed the "threshold level" of crash severity to help reduce slack in the safety belt. Safety belt pretensioners will also deploy in impending rollover situations.

How long will the airbag remain inflated?

It takes approximately 1/20th of a second to fully inflate the frontal airbags. This is faster than the blink of an eye. The airbags begin to deflate immediately, helping to stop the occupants more gradually. Unlike frontal airbags, head curtain side airbags can remain inflated for more than 5 seconds before they start to deflate.

I've heard that a deployed airbag produces what appears to be smoke, is the airbag hot?

After the bag has deployed in a crash, the airbag itself will not be hot to touch. Some components within the airbag module will be hot for a short time. A small amount of smoke coming from a deployed airbag module is normal and should not be cause for concern.

Also, when the nitrogen gas is vented out of the airbag, small particles from inside the bag are also vented into passenger compartment. These airborne particles look like smoke and some particles are deposited as residue on and around the airbag.

I've heard that the dusts that are released into the passenger compartment from the airbag are harmful, is this true?

For most people, the only effect the dusts will produce is some irritation of the throat and eyes, and that is only if the occupant remains in the vehicle for many minutes after the airbag deployment with no ventilation and windows closed. However, some people with asthma may develop an asthmatic attack from inhaling the dusts. If this happens, they should first treat themselves the same way their doctor has advised them to treat any other asthma attack, and then immediately seek medical treatment.

Can the airbag system be re-used?

No. The airbags are designed to inflate only once. After inflation, some new parts will be required. These will include the airbag module and possibly other parts. (A competent service technician with access to the vehicle's service manual and the required tools should replace the required components after a deployment crash.)

If my vehicle has airbags, why should I have to wear my safety belt?

Yes, safety belts are the primary safety restraint in the vehicle. Airbags are in many vehicles today and will be in most of them in the future. But they are supplemental systems only; so they work with safety belts, not instead of them. Every airbag system ever offered for sale has required the use of safety belts. Even if you're in a vehicle that has airbags, you still have to buckle up to get the most protection. That's true not only in frontal collisions but especially in side and other collisions.

ELECTRONIC STABILITY CONTROL SYSTEMS (STABILITRAK)

StabiliTrak systems help drivers maintain control of their vehicles, especially during emergency lane changes or avoidance maneuvers. StabiliTrak uses various sensors, such as steering wheel angle, wheel speed, yaw velocity, etc., to detect any difference between the path requested by the steering wheel position and vehicle's actual path. When appropriate, the system selectively controls brakes, engine power, and even suspension settings to enhance control of the vehicle's direction and help keep it on course.

Independent studies conducted by the National Highway Traffic Safety Administration, the Insurance Institute for Highway Safety, and others have found StabiliTrak to be highly effective in reducing vehicle crashes. General Motors offers StabiliTrak systems on many of its passenger car and light truck models.

See your owner's manual for additional information about the operation of StabiliTrak.

Q. How do I use StabiliTrak?

A. StabiliTrak operates independently of the driver. You should continue to drive your StabiliTrak equipped vehicle with caution and care. GM's StabiliTrak system, StabiliTrak is designed to be as seamless as possible in operation, and part of the overall vehicle response to make a good vehicle better

Q. How does StabiliTrak work?

A. StabiliTrak has the ability to apply control forces to the vehicle independent of the driver. StabiliTrak uses sensors to continuously compare the path indicated by the steering wheel position to the vehicle's actual path. If a discrepancy is detected, StabiliTrak selectively controls vehicle brakes and engine torque to create a yaw moment that helps restore the vehicle's actual path to the path indicated by the steering wheel position. StabiliTrak has the ability to help correct both understeer (where the vehicle is not turning as much as the steering wheel position indicates) and oversteer (where the vehicle is turning more than the steering wheel position indicates).

Q. Will a tire change affect StabiliTrak?

A. Use of tires other than original equipment may affect StabiliTrak performance. StabiliTrak is designed to make the best use of available traction. The performance characteristics of the original equipment tires are part of the overall system effectiveness. When you replace tires check the recommendations in your owner's manual. On GM vehicles, the original equipment tires have a "TPC" (Tire Performance Criteria) code on the sidewall. Replacing the tires with the same "TPC" code will help assure proper StabiliTrak performance.

DRIVER OPERATED STABILITRAK BUTTON

An advanced computer controlled stability enhancement system assists the driver with directional control of the vehicle in difficult driving conditions. Each time the vehicle is started, the StabiliTrak system is fully on. StabiliTrak can be controlled by a button located on the left side of instrument panel. The condition system is displayed by a StabiliTrak indicator light and Driver Information Center (DIC) Message. Push once to disable Traction Control. Push and hold to disable both Traction Control and StabiliTrak. In this condition, StabiliTrak will automatically turn ON when the vehicle speed exceeds 35 mph (56km/hr) while the Traction Control remains OFF. Push again to enable Traction Control and StabiliTrak.

MAINTENANCE / WARRANTY

MAINTENANCE	<p>2-Year Scheduled Maintenance includes only the following: 2-year/24,000-mile Scheduled Maintenance (whichever comes first; up to a total of two service events): ACDelco dexos1®Oil and ACDelco Oil Filter Change (excludes Spark EV) 4-wheel Tire Rotation (excludes dual rear wheel vehicles, all Corvette models and select Camaro models - ZL1 model and 1LE package cars – due to their unidirectional tires; see Owner’s Manual for details) 27-Point Vehicle Inspection (MPVI)</p>
WARRANTY	<p>BUMPER-TO-BUMPER (INCLUDING TIRES) Coverage is for the first 3 years or 36,000 miles, whichever comes first.</p>
POWERTRAIN	<p>In addition to the 3-year/36,000 mile protection, many of your powertrain components are protected even further with coverage extending to 5 years or 60,000 miles, whichever comes first. Coverage for 2500 and 3500 Series Heavy Duty (HD) Pickups equipped with a 6.6L Duramax, and qualifying fleet vehicles is for 5 years or 100,000 miles, whichever comes first.details.</p>
ENGINE	<p>Engine coverage includes all internally lubricated parts, engine oil cooling hoses, and lines. Also included are all actuators and electrical components internal to the engine (e.g., Active Fuel Management valve, lifter and oil manifold) cylinder head, block, timing gears, timing chain, timing cover, oil pump/oil pump housing, OHC carriers, valve covers, oil pan, seals, gaskets, manifolds, flywheel, water pump, harmonic balancer, engine mount, turbocharger, and supercharger. Timing belts are covered until the first scheduled maintenance interval. Exclusions: Excluded from the powertrain coverage are sensors, wiring, connectors, engine radiator, coolant hoses, coolant, and heater core. Coverage on the engine cooling system begins at the inlet to the water pump and ends with the thermostat housing and/or outlet that attaches to the return hose. Also excluded is the starter motor, entire pressurized fuel system (in-tank fuel pump, pressure lines, fuel rail(s), regulator, injectors, and return line), as well as the Engine/ Powertrain Control Module and/or module programming.</p>
DIESEL ENGINE/ COMPONENTS	<p>Cylinder block and heads and all internal parts, intake and exhaust manifolds, timing gears, timing gear chain or belt and cover, flywheel, harmonic balancer, valve covers, oil pan, oil pump, water pump, fuel pump, engine mounts, seals, and gaskets. Parts of the Emissions Reduction System such as the emissions reduction fluid tank, injectors, sensors including NOx and exhaust, and the Exhaust Particulate Filter. Glow Plug Control System: Control/glow plug assembly, glow plugs, cold advance relay, and engine control module The fuel injection control module, integral oil cooler, transmission adapter plate, common fuel rails, fuel filter assembly, fuel temperature sensor, and function block.</p>
TRANSMISSION/ TRANSAXLE	<p>Transmission and transaxle coverage includes all internally lubricated parts, case, torque converter, mounts, seals and gaskets, as well as any electrical components internal to the transmission/transaxle. Also covered are any actuators directly connected to the transmission (slave cylinder, etc.). Exclusions: Exclusions from the powertrain coverage include cooling lines, hoses, radiator, sensors, wiring, and electrical connectors. Also excluded are the clutch and pressure plate, as well as any Transmission Control Module and/or module programming.</p>
TRANSFER CASE	<p>Transfer case coverage includes all internally lubricated parts, case, mounts, seals and gaskets, as well as any electrical components internal to the transfer case. Also covered are any actuators directly connected to the transfer case, as well as the encoder motor. Exclusions: Excluded from the powertrain coverage are transfer case cooling lines, hoses, radiator, sensors, wiring, and electrical connectors, as well as the transfer case control module and/or module programming.</p>
DRIVE SYSTEMS	<p>Drive system coverage includes all internally lubricated parts, final drive housings, axle shafts and bearings, constant velocity joints, propeller shafts and universal joints. All mounts, supports, seals, and gaskets, as well as any electrical components internal to the drive axle. Also covered are any actuators directly connected to the drive axle (e.g., front differential actuator). Exclusions: Excluded from the powertrain coverage are all wheel bearings, drive wheel front and rear hub bearings, locking hubs, drive system cooling, lines, hoses, radiator, sensors, wiring, and electrical connectors related to drive systems, as well as any drive system control module and or module programming.</p>
SHEET METAL	<p>GM vehicles are designed and built to resist corrosion. All body and sheet metal components are warranted against corrosion for 3 years or 36,000 miles, whichever comes first. Plus you’re protected even further from rust-through corrosion for a minimum of 6 years/100,000 miles (whichever comes first). Application of additional rust-inhibiting materials is not required under the corrosion coverage and none is recommended. See your GM dealer for terms of this limited warranty.</p>

MAINTENANCE / WARRANTY

<p>EMISSION CONTROL SYSTEMS</p>	<p>Defects and performance for car and light-duty truck emission control systems are covered for the first 2 years or 24,000 miles, whichever comes first. From the first 2 years or 24,000 miles to 3 years or 36,000 miles defects in material or workmanship continue to be covered under the New Vehicle Limited Bumper-to-Bumper Warranty coverage. Specified major components are covered for the first 8 years or 80,000 miles, whichever comes first. Defects and performance for heavy duty truck emission control systems including those found in 6.6L Duramax® Diesel Engines are covered for the first 5 years or 50,000 miles, whichever comes first.</p> <p>- Refer to your Warranty and Owner Assistance Information booklet for California emission control system warranty details.</p>
<p>TIRES</p>	<p>The tires supplied with your vehicle are covered by General Motors against defects in material or workmanship under the Bumper-to-Bumper Limited Warranty coverage. Wear-out is not considered a defect, and it may occur before the vehicle warranty expires. In this case, the owner is responsible for purchasing replacement tires, or seeking coverage solely from the tire manufacturer. For vehicles within the Bumper-to-Bumper Limited Warranty coverage, defective tires will be replaced on a prorated adjustment basis according to the mileage-based schedule in your Warranty and Owner Assistance Information booklet. After your New-Vehicle Limited Warranty expires, you may still have prorated warranty coverage on your original equipment tires by the tire manufacturer.</p>
<p>TOWING</p>	<p>Towing is covered to the nearest Chevrolet dealer if your vehicle cannot be driven because of a warranted defect.</p>
<p>COURTESY TRANSPORTATION</p>	<p>If your vehicle requires warranty repairs during the Limited Powertrain Warranty coverage period (8 years/100,000 miles for repairs warrantable under the Hybrid/Electric Propulsion Limited Warranty), alternate transportation and/or reimbursement of certain transportation expenses may be available under the Courtesy Transportation Program. Several transportation options are available. Consult your dealer or refer to the Owner's Manual for details. Courtesy Transportation is not part of or included in the coverage provided by the New-Vehicle Limited Warranty. General Motors reserves the right to make any changes or discontinue the Courtesy Transportation program at any time without notification.</p>
<p>ROADSIDE ASSISTANCE</p>	<p>Chevrolet is proud to offer the response, security and convenience of the 24-Hour Roadside Assistance Program. Roadside Assistance is provided with all purchased or leased GM vehicles that are within the Powertrain Limited Warranty.</p> <ul style="list-style-type: none"> Emergency Towing (from a public road or highway to nearest Chevrolet dealer) Lockout Service (keys locked inside vehicle) Flat Tire Changes (service to change a flat tire with the spare tire (if equipped)) Fuel Delivery (enough fuel for vehicle to get to the nearest service station) Jump-Starts (service to jumpstart a dead battery) <p>During the 8 year or 100,000 miles Electric Propulsion warranty period, towing is covered to the nearest Chevrolet servicing dealer if your vehicle cannot be driven because of a warranted Electric Propulsion specific defect.</p> <p>Refer to your Owner's Manual for details, including reservation of rights, or consult your dealer/retailer. --For specific terms and conditions, please contact your Chevrolet Roadside Assistance Program advisor at 1-800-243-8872.</p>
<p>WHAT IS NOT COVERED</p>	<p>All the above items are not covered for damage due to accident, misuse, alteration, insufficient or improper maintenance, contaminated or poor-quality fuel or environmental and chemical exposure. For complete details, refer to your Warranty and Owner Assistance Information booklet.</p> <p>This is a supplement to the express conditions and warranties described in the Warranty and Owner Assistance Information booklet. Other coverages are not extended or altered due to this supplement.</p> <p>Passenger car, light-duty truck, crossover and van owners requiring a more comprehensive coverage than what is provided with the New-Vehicle Limited Warranty are encouraged to consider a Chevrolet Protection Plan. This plan is available through Chevrolet dealerships. For more information, see the Extended Protection section on www.chevrolet.com/owners/warranty.html.</p>
<p>ALTERATIONS AND WARRANTIES</p>	<p>AN IMPORTANT NOTE ABOUT ALTERATIONS AND WARRANTIES. The Chevrolet New Vehicle Limited Warranty does not cover any damage or failure resulting from modifications, installations, or alterations to the original equipment as manufactured or assembled by General Motors. The special body company, assembler, equipment installer or upfitter is solely responsible for warranties on the body or equipment and any alterations (or any effect of the alterations) to any of the parts, components, systems or assemblies installed by GM. General Motors is not responsible for the safety or quality of design features, materials or workmanship of any alterations by such suppliers.</p>



LS Model shown with after-market equipment

GM reserves the right to make changes at any time, without notice, in prices, colors, materials, equipment, specifications, models, and availability. Specifications, dimensions, measurements, ratings, and other numbers in this catalog and other printed materials provided at the dealership or affixed to vehicles are approximates based upon design and engineering drawings and prototypes and laboratory tests. Your vehicle may differ due to variations in manufacture and equipment. Since some information may have been updated since the time of printing, please check with your GM dealer for complete details. Some of the equipment shown or described throughout this publication may be available at extra cost, and/or is supplied by an independent supplier.

©2015 General Motors. All rights reserved. All text, images, graphics, and other materials in this publication are subject to the copyright and other intellectual property rights of General Motors. These materials may not be reproduced, distributed, or modified without the express written permission of General Motors. The marks appearing in this publication including, but not limited to: GM and the GM logo; Chevrolet and their respective logos, emblems, slogans, and vehicle model names and body designs; and other marks such as GM Fleet and Commercial are trademarks and/or service marks of General Motors, its subsidiaries, affiliates, or licensors.

For more detailed information, contact your District Sales Manager or see the online order guide at gmfleet.com.



For more information, visit gmfleet.com/police

GENERAL MOTORS FLEET

